

The 700382-12 GT30R is a customizable Garrett ball bearing GT turbo that is packaged without the turbine housing. (it includes a CHRA and compressor housing). Either 740902-1 or 740902-2 turbine housing kits are available.

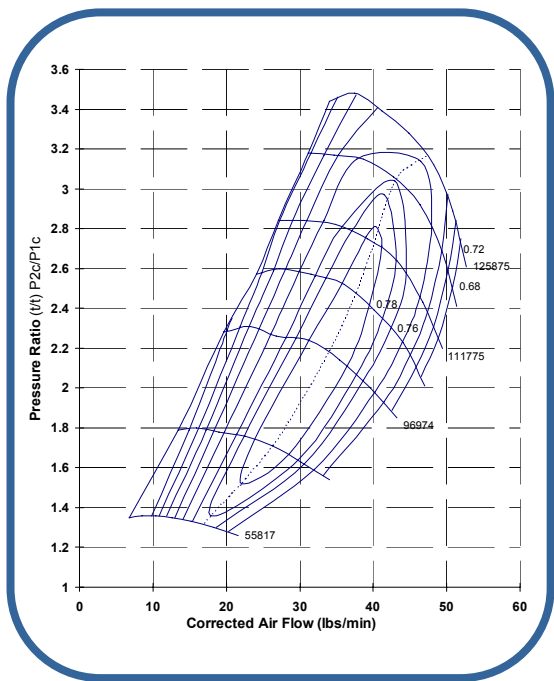

POWERSHIFT
 Horsepower 300 – 500
 Displacement 2.0 – 3.0L

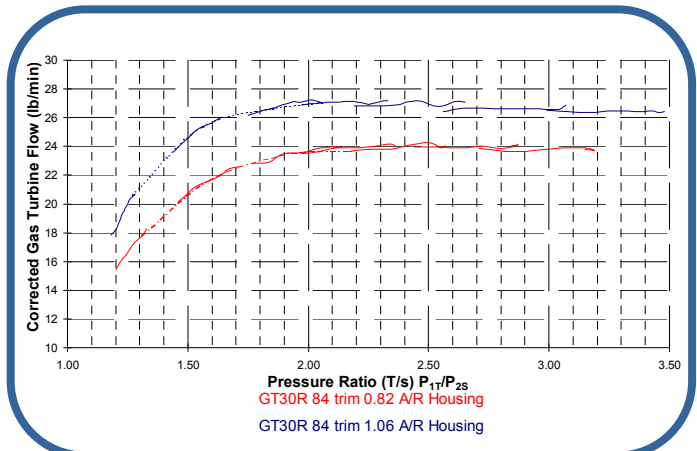
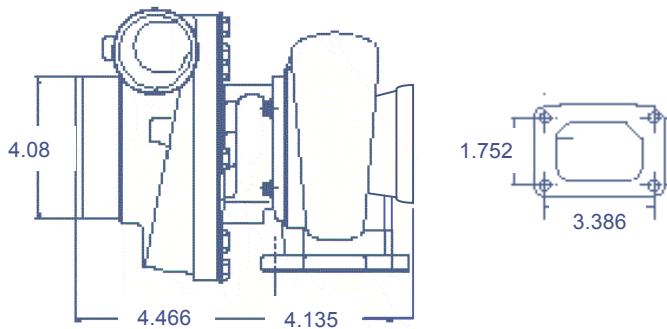
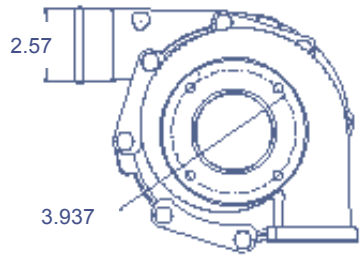

Turbo	COMPRESSOR			TURBINE WHEEL			
	Wh Dia	Trim	A/R	Wh Dia	Trim	A/R	Type
GT30R 700382-12	76.2mm	56	0.6	60mm	84	---	---

TURBINE HSG KITS				
740902-1	---	---	1.06	free float
740902-2	---	---	0.82	free float

The turbine housing kits include turbine housing, clamps, bolts, and turbine inlet gasket. The housing is designed with T3 inlet flanges and a 4 bolt outlet.

740902-1
 740902-2