



US006484688B1

(12) **United States Patent**  
**Strauss**

(10) **Patent No.:** **US 6,484,688 B1**  
(45) **Date of Patent:** **Nov. 26, 2002**

(54) **CONTROL METHODOLOGY FOR AN INTERNAL COMBUSTION ENGINE THAT UTILIZES A COMBUSTION CONDITION SENSOR**

(75) Inventor: **Sebastian Strauss**, Park City, IL (US)

(73) Assignee: **Bombardier Motor Corporation of America**, Grant, FL (US)

(\* ) Notice: Subject to any disclaimer, the term of this patent is extended or adjusted under 35 U.S.C. 154(b) by 0 days.

(21) Appl. No.: **09/723,860**

(22) Filed: **Nov. 28, 2000**

(51) **Int. Cl.**<sup>7</sup> ..... **F02D 41/14**

(52) **U.S. Cl.** ..... **123/298; 123/679**

(58) **Field of Search** ..... **123/673, 703, 123/305, 435, 298, 679-687**

(56) **References Cited**

U.S. PATENT DOCUMENTS

5,613,480 A \* 3/1997 Katoh et al. .... 123/673  
6,173,690 B1 \* 1/2001 Iriya et al. .... 123/295

\* cited by examiner

*Primary Examiner*—Andrew M. Dolinar

*Assistant Examiner*—Johnny H. Hoang

(74) *Attorney, Agent, or Firm*—Fletcher, Yoder & Van Someren

(57) **ABSTRACT**

An internal combustion engine that utilizes a control system for improving operation of the engine under a variety of conditions. The control system includes a sensor that directly senses a combustion condition in a cylinder. The output of the sensor is utilized in adjusting the air-fuel mixture delivered to other, non-sensed cylinders to optimize engine operation.

**38 Claims, 8 Drawing Sheets**

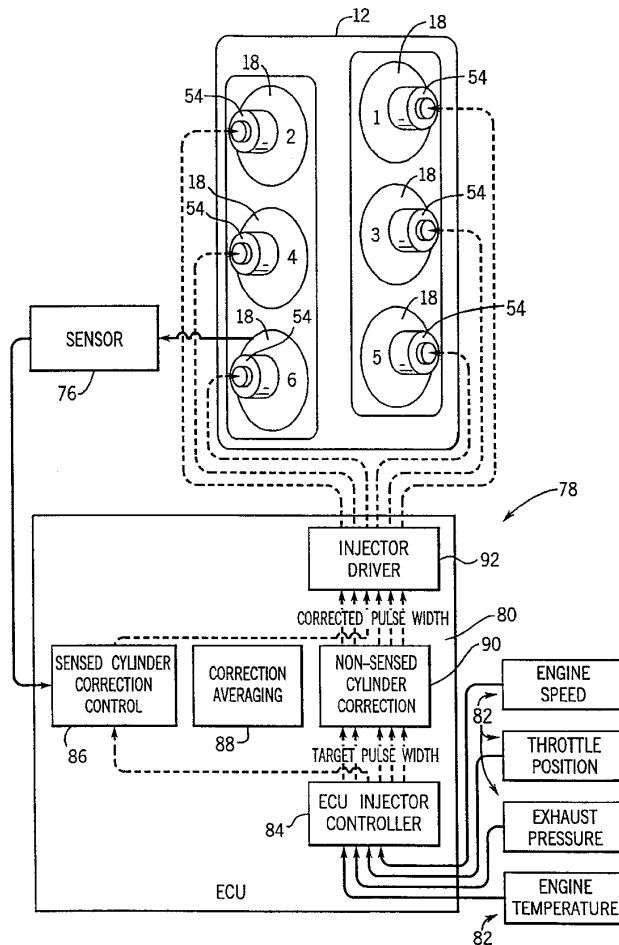
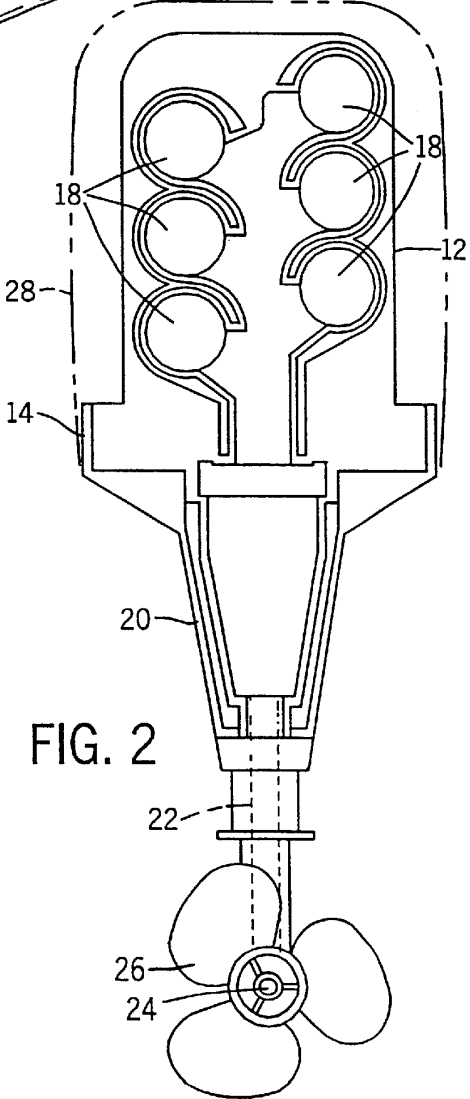
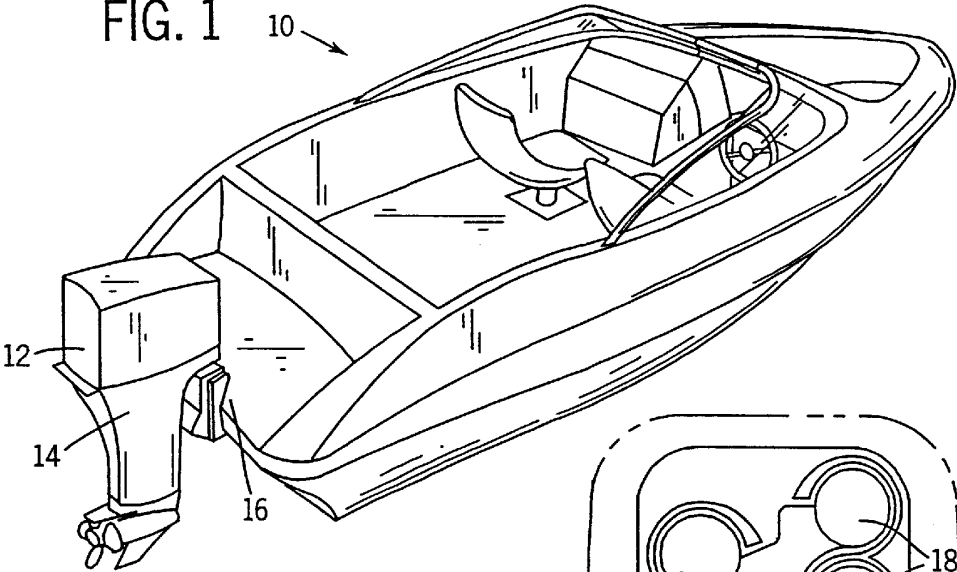

FIG. 1



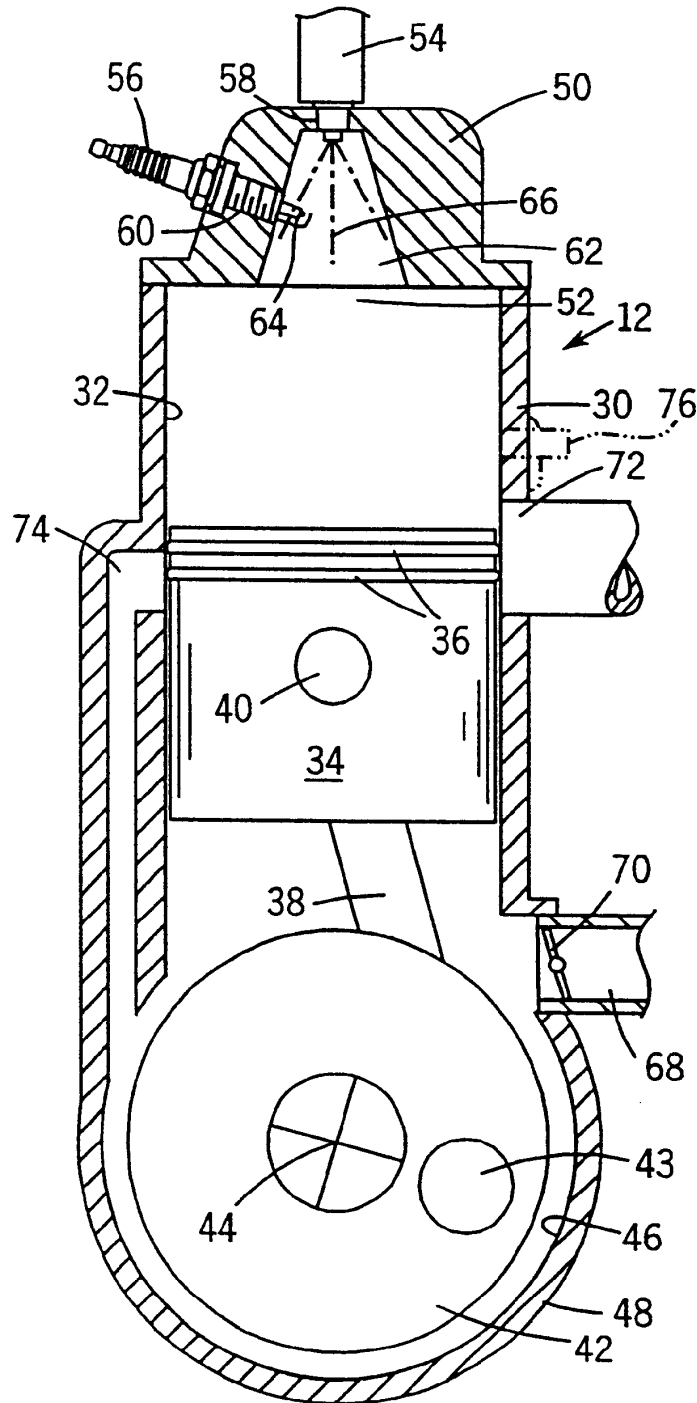

FIG. 3

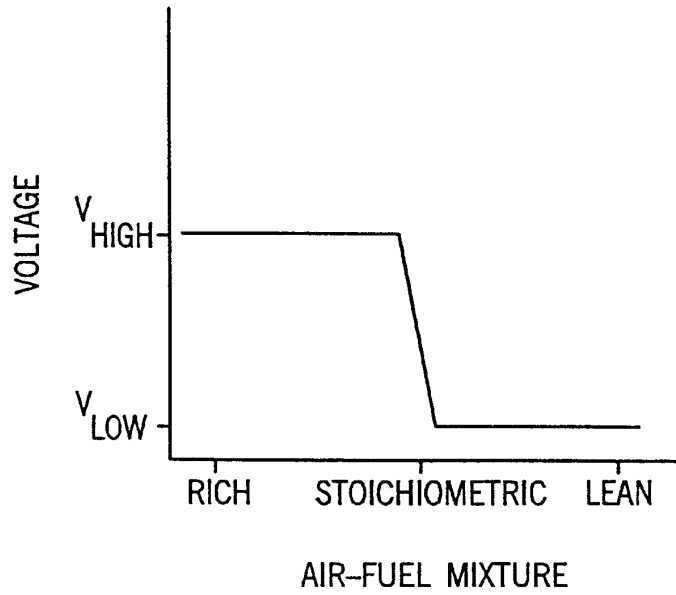
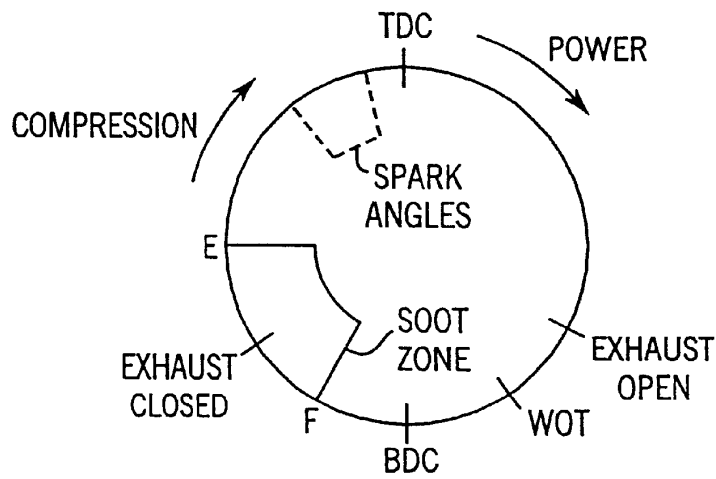

FIG. 4

FIG. 5



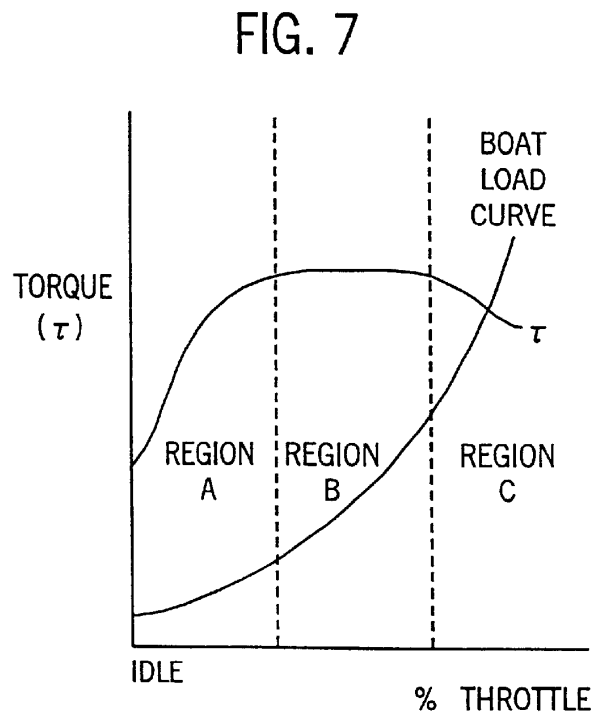
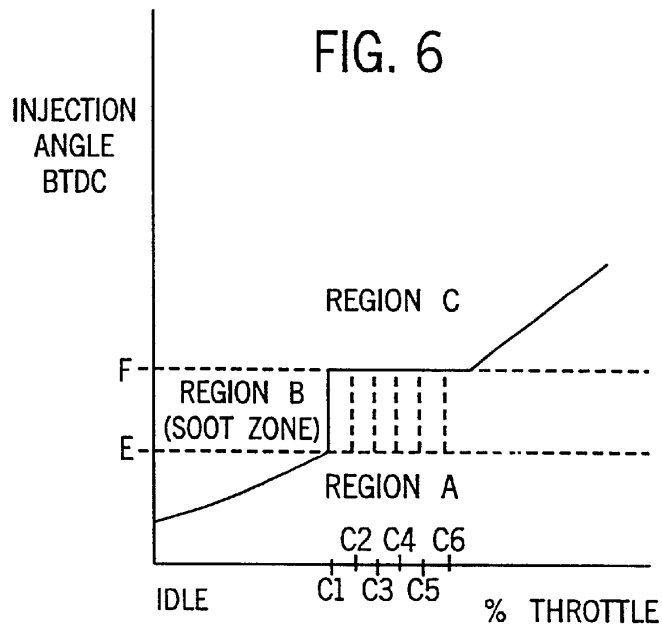
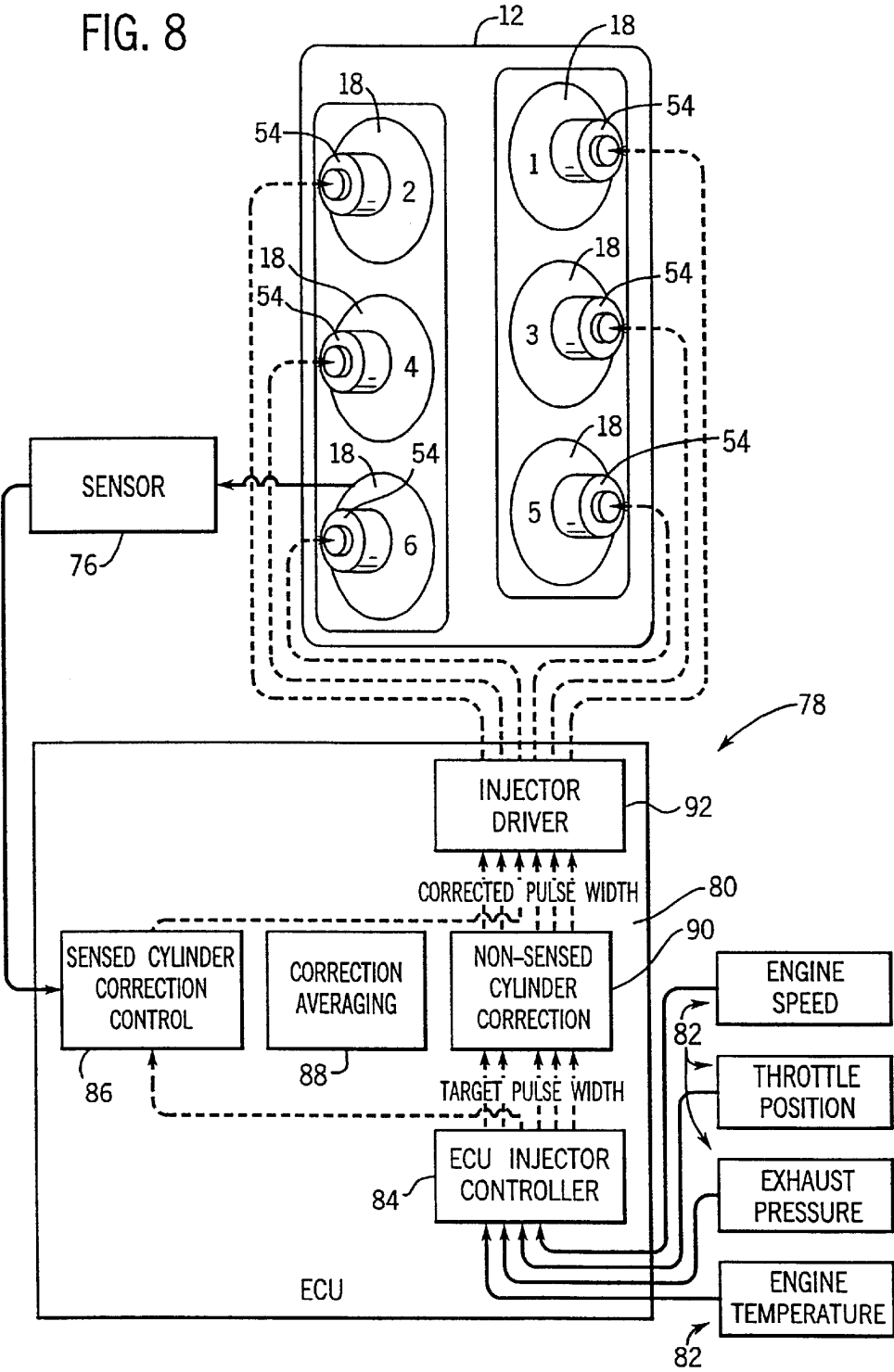

FIG. 8



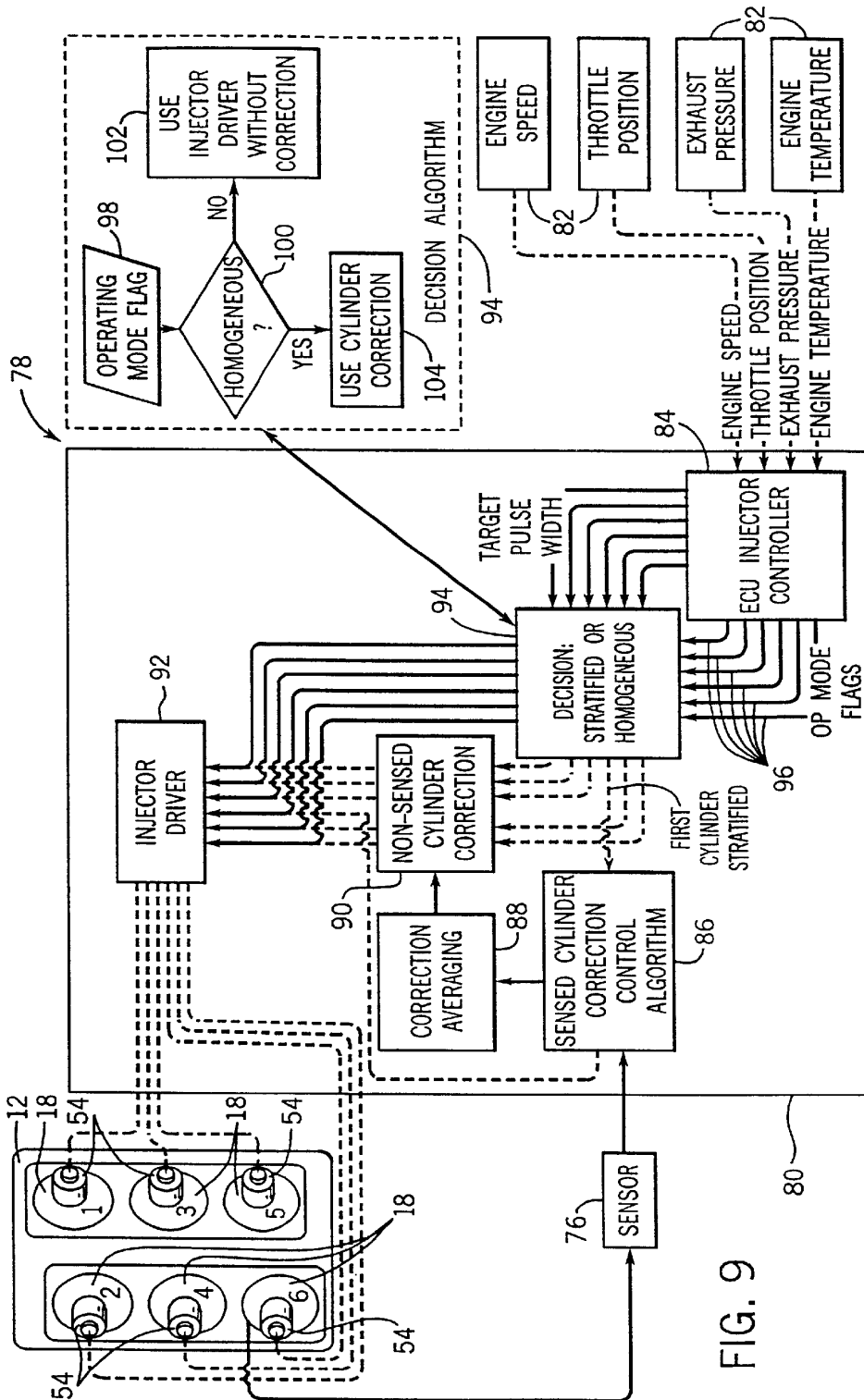

FIG. 9

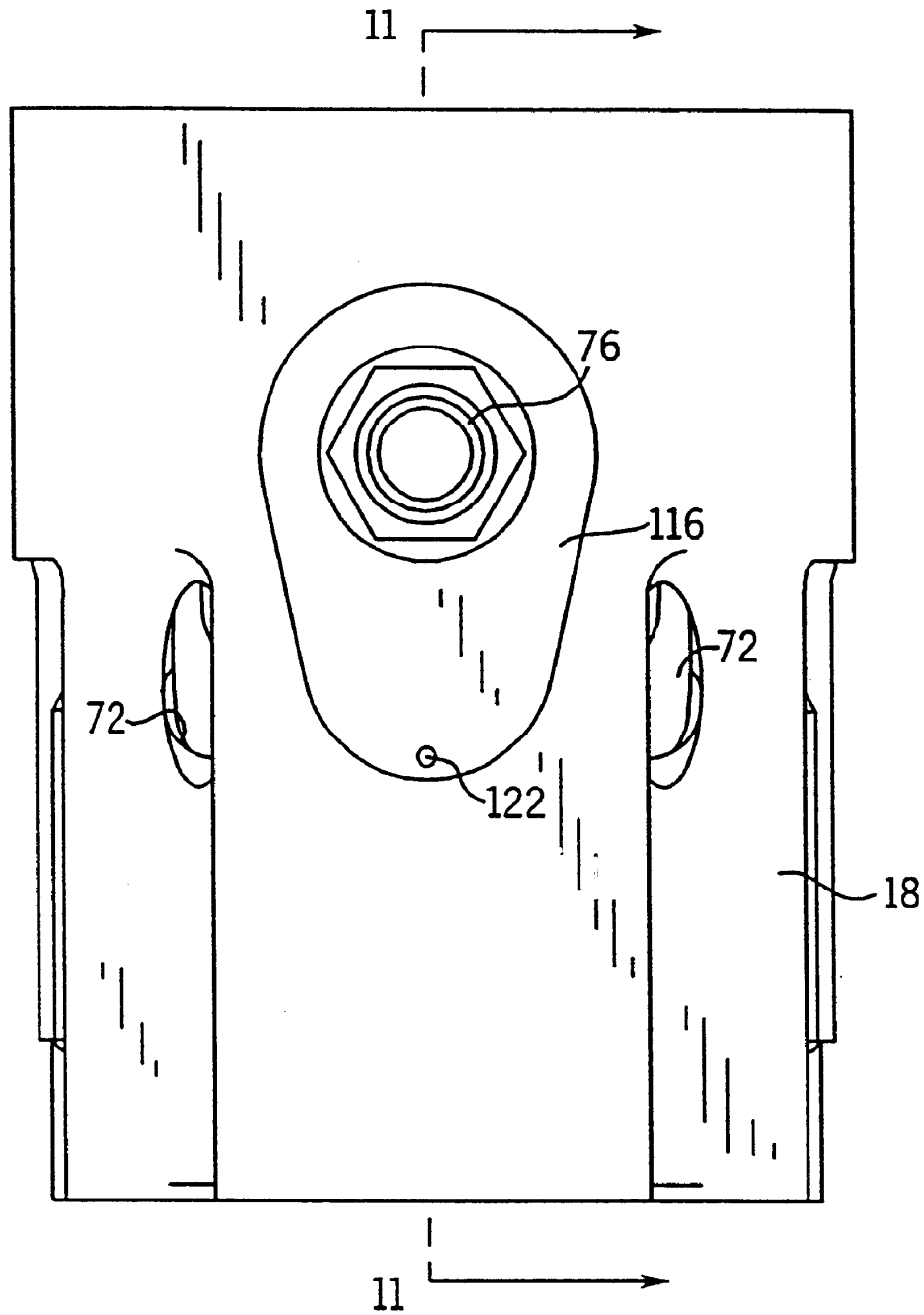
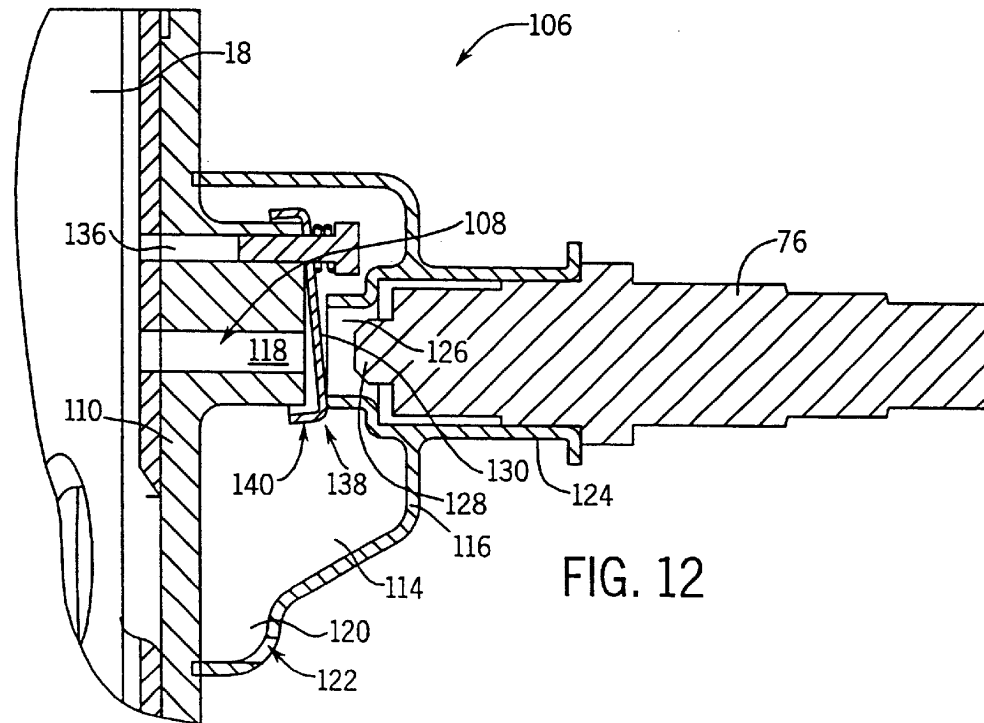
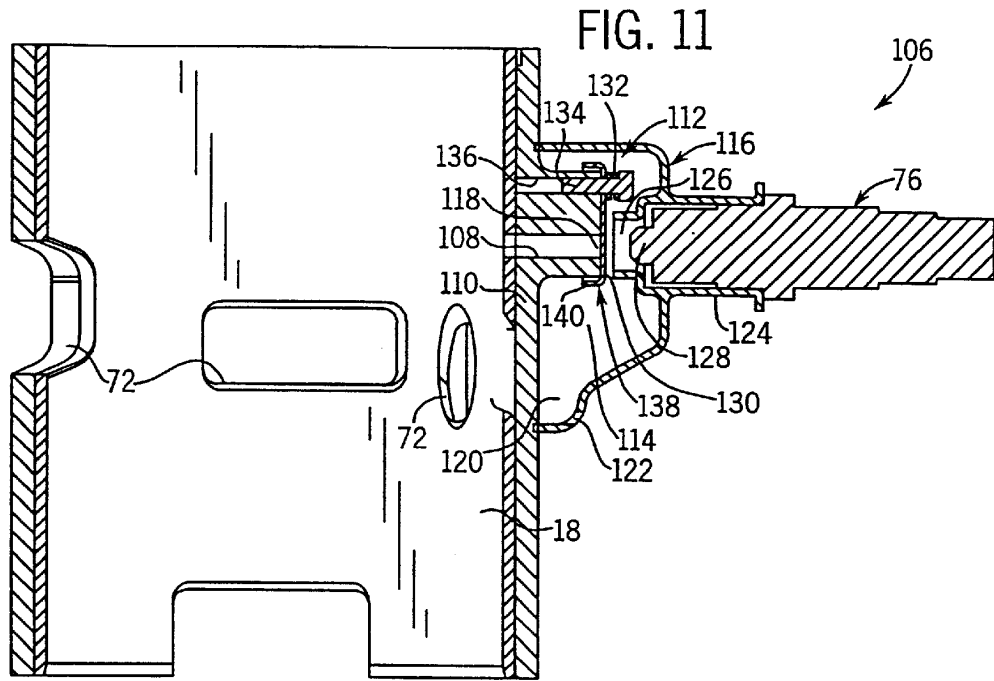

FIG. 10





1

**CONTROL METHODOLOGY FOR AN  
INTERNAL COMBUSTION ENGINE THAT  
UTILIZES A COMBUSTION CONDITION  
SENSOR**

**FIELD OF THE INVENTION**

The present invention relates generally to a system and method for controlling the ignition characteristics of certain internal combustion engines, and particularly to a system and method for utilizing feedback from a combustion condition sensor in one cylinder and utilizing that feedback to adjust the air-fuel mixture to a more optimal ratio in other non-sensed cylinders.

**BACKGROUND OF THE INVENTION**

Internal combustion engines are used in a wide variety of applications, including providing power for a variety of vehicles. Generally, such engines include one or more cylinders that each contain a piston designed for movement in a reciprocating manner. Each piston is connected to a crankshaft by a connecting rod that delivers force from the piston to the crankshaft in a manner that rotates the crankshaft. Power to drive the piston is provided by igniting an air-fuel mixture supplied to the cylinder on a side of the piston opposite the connecting rod. The air-fuel mixture is ignited by some type of ignition device, e.g. providing a spark across electrodes of a spark plug.

Air and fuel may be supplied to each cylinder by a variety of mechanisms, such as a fuel injection system. Regardless of how the air-fuel mixture is established, it is necessary to adjust or change the air-fuel mixture according to operating conditions. For example, application of greater throttle for increased engine speed requires a greater quantity of fuel. On the other hand, maintaining the engine operation at a lower rpm, requires a lesser quantity of fuel supplied to each cylinder. Generally, greater control over combustion conditions, e.g. air-fuel mixture, provides an engine designer with a greater ability to bring about a desired engine performance under a greater range of operating conditions.

Modern engines often utilize electronic fuel injection systems that inject specific amounts of fuel based on a stored fuel map. The fuel map effectively acts as a guide as to fuel injection quantities based on a variety of sensed parameters, such as engine speed, throttle position, exhaust pressure and engine temperature. However, none of these inputs are based on the actual combustion taking place in the one or more cylinders.

In some applications, oxygen sensors have been used to sense oxygen content of the combustion products, i.e. exhaust gasses. However, the sensed information has not been fully utilized in optimizing the air-fuel ratio in both sensed and non-sensed cylinders. It would be advantageous to have a methodology for correcting, for example, a fuel map controlling the fuel delivered to both sensed and non-sensed cylinders.

**SUMMARY OF THE INVENTION**

The present invention features a method for controlling the operation of an internal combustion engine having a plurality of cylinders and a controller that utilizes a fuel map. The method includes sensing a combustion condition in a sensed cylinder of an internal combustion engine. The method further includes determining whether the combustion condition is a desired combustion condition under the

2

current operating parameters. The method also includes utilizing the difference between the combustion condition and the desired combustion condition to correct the fuel amounts introduced into a non-sensed cylinder.

According to another aspect of the present invention, a method is provided for controlling the operation of a watercraft. The method includes powering a watercraft with an internal combustion engine having a plurality of cylinders in which a cylinder of the plurality of cylinders is sensed for a specific combustion condition. The method also includes determining whether the combustion condition is desired under the current operating parameters and the comparing the actual combustion condition to a desired combustion condition. The fuel amount introduced into a non-sensed cylinder is then corrected based on the sensed combustion condition.

According to another aspect of the invention, a system is provided for controlling combustion in an internal combustion engine. The system includes a direct, fuel-injected, two-stroke engine having a plurality of cylinders with each cylinder being coupled to a fuel injector and a pair of electrodes for producing an ignition spark. The system further includes a combustion condition sensor coupled to a sensed cylinder of the plurality of cylinders. The sensor is able to produce an output indicative of the combustion condition. Also, the system includes a control unit having a pre-established fuel map for injecting specific quantities of fuel into each cylinder under a given operating condition. The control unit is able to adjust the fuel map for non-sensed cylinders based on the output of the combustion condition sensor.

**BRIEF DESCRIPTION OF THE DRAWINGS**

The invention will hereafter be described with reference to the accompanying drawings, wherein like reference numerals denote like elements, and:

FIG. 1 a perspective view of a watercraft powered by an exemplary engine, according to an embodiment of the present invention;

FIG. 2 is a schematic representation of the outboard motor illustrated in FIG. 1;

FIG. 3 is a schematic cross-sectional view of a single cylinder in an exemplary two-stroke engine having a sensor to sense a combustion condition;

FIG. 4 is a graphical representation of the output of a passive-type oxygen sensor as the air-fuel mixture varies through a stoichiometric mixture from rich to lean;

FIG. 5 is a graphical representation of a single revolution of an engine crankshaft with respect to the location of a piston in a cylinder;

FIG. 6 is a graphical representation of injection angle before top dead center (BTDC) versus percent throttle for an exemplary engine;

FIG. 7 is a graphical representation of torque versus percent throttle for an exemplary engine;

FIG. 8 is a schematic illustration of a control system connected to an exemplary engine, according to an exemplary embodiment of the present invention;

FIG. 9 is a schematic illustration similar to FIG. 8 but showing additional features of the control system;

FIG. 10 is a partial side view of an engine cylinder to which a combustion condition sensor is mounted;

FIG. 11 is a cross-sectional view taken generally along line 11—11 of FIG. 10; and

FIG. 12 is a cross-sectional view similar to FIG. 11 but showing the opening of a pressure valve to release exhaust gasses to the combustion condition sensor.

#### DETAILED DESCRIPTION OF THE PREFERRED EMBODIMENTS

For the sake of clarity in explanation, the present invention is described in conjunction with engines that operate on a two-stroke cycle and utilize fuel injection. The present system and method are particularly amenable for use in two-stroke engines that inject fuel, such as gasoline, directly into each cylinder of the engine. The exemplary embodiment described herein should not be construed as limiting, however, and has potential uses in other types of two-stroke and four-stroke engine applications that may benefit from a control system that uniquely utilizes the sensing of combustion end products, e.g. exhaust gasses, to adjust the air-fuel mixture introduced into one or more of the engine cylinders.

Referring generally to FIG. 1, an exemplary application of the present system is illustrated. In this application, a watercraft 10, such as a boat, is powered by an engine 12 disposed in an outboard motor 14. Watercraft 10 can also be a personal watercraft or boat having an internally mounted engine. In the illustrated embodiment, outboard motor 14 is mounted to a transom 16 of watercraft 10. Engine 12 is a two-stroke engine that utilizes direct fuel injection, as explained more fully below.

Although engine 12 may be a single cylinder engine, it often includes a plurality of cylinders 18, e.g. six cylinders, as illustrated schematically in FIG. 2. In the application described above, engine 12 is mounted to an outboard motor frame 20 that supports engine 12 and encloses a drive shaft 22. Generally, drive shaft 22 is vertical and connects to an output shaft 24 to which a propeller 26 is mounted. Engine 12 rotates drive shaft 22 which, in turn, rotates output shaft 24. Output shaft 24 is connected to propeller 26 by, for example, splines that rotate the propeller to drive watercraft 10 along the surface of the water. A shroud or housing 28 encloses engine 12.

Referring generally to FIG. 3, a single cylinder of an exemplary two-stroke engine 12 is illustrated. In this embodiment, engine 12 includes a cylinder 30 having an internal cylinder bore 32 through which a piston 34 reciprocates. Piston 34 typically includes one or more rings 36 that promote a better seal between piston 34 and cylinder bore 32 as piston 34 reciprocates within cylinder 30.

Piston 34 is coupled to a connecting rod 38 by a pin 40, sometimes referred to as a wrist pin. Opposite pin 40, connecting rod 38 is connected to a crankshaft 42 at a location 43 offset from a crankshaft central axis 44. Crankshaft 42 rotates about axis 44 in a crankshaft chamber 46 defined by a housing 48.

At an end of cylinder 30 opposite crankshaft housing 48, a cylinder head 50 is mounted to cylinder 30 to define a combustion chamber 52. Cylinder head 50 may be used to mount a fuel injector 54 and a spark plug 56, which are received in a pair of openings 58 and 60, respectively. Openings 58 and 60 may be formed through the wall that forms either cylinder head 50 or cylinder 30. In the illustrated embodiment, openings 58 and 60 are formed through the wall of cylinder head 50 for communication with combustion chamber 52 within a recessed internal region 62 of cylinder head 50.

By way of example, fuel injector 54 may be centrally located at the top of cylinder head 50, as illustrated in FIG. 3. Spark plug 56 preferably is disposed at an angle such that

its electrodes 64, and consequently the spark, are positioned in an actual fuel spray pattern 66. Fuel spray pattern 66 is the "cone" or other pattern of fuel spray injected by fuel injector 54.

In operation, piston 34 travels towards cylinder head 50 to compress a charge of air within combustion chamber 52. Simultaneously, fuel injector 54 injects fuel to create an air-fuel mixture that is ignited by an appropriately timed spark across electrodes 64. As piston 34 travels towards cylinder head 50, air is drawn through an inlet port 68 into crankshaft chamber 46 and cylinder 30 on a side of piston 34 opposite combustion chamber 52. A valve 70, such as a reed valve, allows the air to pass into engine 12 but prevents escape back through inlet port 68.

Upon ignition of the air-fuel charge in combustion chamber 52, piston 34 is driven away from cylinder head 50 past an exhaust port 72 through which the exhaust gasses are discharged. As piston 34 moves past exhaust port 72, it ultimately exposes a transfer port 74. Air from crankshaft chamber 46 is forced through port 74 and into cylinder 30 on the combustion chamber side of piston 34. Effectively, the downward travel of piston 34 compresses the air in crankshaft chamber 46 and forces a fresh charge of air into cylinder 30 through transfer port 74 for the next ignition.

This reciprocal motion of piston 34 drives connecting rod 38 and crankshaft 32 to provide power to, for example, drive shaft 22 of outboard motor 14. To provide the desired power to crankshaft 42, it is necessary that ignition of the air-fuel mixture be carefully timed. If the ignition occurs too early, the resultant explosion works against the progress of piston 34 towards cylinder head 50. On the other hand, if ignition is too late, less power is transferred to piston 34.

Additionally, it is beneficial to optimize the air-fuel mixture introduced into a given cylinder to promote a desired result, e.g. power, efficiency of operation, reduced soot, etc. Existing fuel injection systems rely on various sensed parameters, such as throttle position, to adjust the amount of fuel injected. However, as illustrated in FIG. 3, a combustion condition sensor 76 is used to directly sense a combustion condition based on the by-products of combustion in the cylinder.

An exemplary combustion condition sensor 76 is an oxygen sensor. Oxygen sensors may be utilized in a variety of ways to determine the oxygen content of exhaust gasses resulting from combustion that occurs in a cylinder, such as cylinder 30. If no other constituents are introduced into the exhaust gasses, determination of the oxygen content can be used, for example, to determine whether the combustion that occurred had an air-fuel mixture that was stoichiometric. The oxygen sensor also can be used to determine whether the air-fuel mixture was rich or lean relative to the stoichiometric combustion mixture.

Exemplary oxygen sensors include active sensors, which may be wide range or narrow band, and passive sensors. Active oxygen sensors output a voltage signal that increases as the air-fuel mixture becomes increasingly lean. On the other hand, passive oxygen sensors that are narrow band output a higher voltage when the air-fuel mixture is rich relative to stoichiometric, and output a low voltage signal when the air-fuel mixture is lean relative to stoichiometric, as illustrated in FIG. 4. Passive oxygen sensors tend to be substantially less expensive than active oxygen sensors, but can only be used to determine whether the air-fuel mixture is either rich or lean of a stoichiometric mixture. Although an active oxygen sensor can be utilized in the present invention, the embodiments described below utilize a more

5

economical passive oxygen sensor, such as a zirconium oxide-type galvanic heated oxygen sensor.

The present invention allows the use of a combustion condition sensor, e.g. an oxygen sensor, in cooperation with a control system to determine a specific combustion condition in one or more cylinders and to compare this to previously mapped fuel quantities. Based on the comparison, a correction factor is determined and applied to the other cylinders of the engine regardless of whether the desired air-fuel ratio for the other cylinders is different from that of the sensed cylinder.

For example, the present control system and method is particularly amenable for use in fuel-injected, two-stroke engines, such as the direct injection engine described above. A passive oxygen sensor **76** is utilized in a single cylinder to determine whether combustion is occurring at a rich or lean mixture of fuel and air (i.e., away from a stoichiometric mixture), and then to change the fuel injection rate to trim the rich or lean mixture towards a desired mixture of fuel and air (e.g., towards a stoichiometric mixture) for that single cylinder. The air-fuel mixture may be determined by averaging over a number of engine cycles, which may vary according to operating conditions such as engine speed, throttle position, temperature, and other factors.

For the particular operating condition, the fuel injection rate actually applied to the single cylinder may be compared to a previously stored fuel map value for the desired mixture (e.g., stoichiometric). If the fuel injection rate deviates from the previously mapped value, then a correction factor may be determined to account for the deviation (e.g., a ratio between the actual and mapped fuel injection rates or amounts). Thus, the correction factor adjusts the mapped value to provide the fuel injection rate corresponding to the desired mixture for the particular operating conditions. Accordingly, the correction factor may then be applied to cylinders that do not have a sensor (i.e. non-sensed cylinders), even though the desired air-fuel mixture for those cylinders may not be a stoichiometric mixture at a given set of operating conditions.

Although a sensor **76** can be utilized in more than one cylinder, a single sensor in a single cylinder is often sufficient. For example, in the boat motor **14**, a single cylinder can be sensed to determine a correction factor which is then applied to the five non-sensed cylinders as follows.

A passive oxygen sensor, e.g. sensor **76**, continuously determines a specific combustion condition, e.g. a stoichiometric mixture, by continuously adjusting the fuel delivery to the sensed cylinder on a periodic basis. For example, if the sensor indicates a fuel mixture rich of stoichiometric, the amount of fuel injected is periodically decreased, until the sensor indicates the mixture is lean of stoichiometric. The amount of fuel injected is then periodically increased until the sensor indicates a fuel mixture rich of stoichiometric. This process is continuously repeated and averaged over a certain number of cycles to continuously provide the control system with an indication of the amount of fuel required to achieve stoichiometric combustion for a given set of conditions. The approximate stoichiometric mixture is determined every time the sensor indicates a transition from rich to lean or lean to rich, and the average over a given number of cycles provides an indication of stoichiometric.

Oxygen sensor **76** is best utilized during homogeneous combustion. The stratified combustion that occurs at lower engine speeds may not lend itself to accurate determination of the air-fuel mixture based on the combustion characteristics during stratified combustion. Also, the air-fuel mixture

6

may not be sufficiently indicative of the actual combustion condition. Accordingly, the present system and methodology is particularly adaptable to engines that benefit from a skip strategy in which cylinders are individually and sequentially moved from a stratified combustion mode to a homogeneous combustion mode. This skip strategy has been pioneered by Outboard Marine Corporation and alleviates many of the problems created by soot formation in the transition from stratified combustion mode to homogeneous combustion mode without creating power surges or drops in response to small throttle movements.

By way of further explanation, the direct burning of gasoline droplets in a cylinder can cause soot formation when unvaporized gasoline is burned in the cylinder. In other words, a less desirable air-fuel mixture is formed relative to a homogeneously charged engine. At idle speeds, soot formation is not significant, because the injected fuel quantities are small, and because the fuel droplets are injected into the cylinder at a later stage of the cylinder cycle when greater pressure exists within the cylinder. As the injection timing becomes earlier and injected fuel quantities increase, soot formation can adversely impact engine operation just before the transition from stratified combustion to homogeneous combustion.

By rapidly moving a cylinder through this soot formation stage, the soot formation can be substantially avoided. However, if all cylinders of a multi-cylinder engine are simultaneously moved through the soot formation zone (e.g., by simultaneously changing the fuel injection angles over a range), then a relatively small throttle movement may rapidly change speed due to torque changes from the simultaneous movement. Accordingly, it has been determined that sequential movement of the cylinders from stratified combustion mode to homogeneous combustion mode (or vice versa) largely eliminates soot formation while providing a smooth power transition as the throttle position is increased or decreased. Preferably, oxygen sensor **76** is placed in the first cylinder to be transitioned from stratified combustion mode to homogeneous combustion mode to permit the earliest and most accurate sensing of a combustion condition, such as stoichiometric combustion during homogeneous operation.

FIG. 5 provides a graphical representation of one complete revolution of crankshaft **42** with respect to the location of piston **34** in cylinder **30**, and further illustrates the step function control strategy described with respect to FIG. 5. Starting with piston **34** located at top dead center (TDC), piston **34** is drawn toward crankshaft **42** in a power stroke. At a predefined angle from TDC, piston **34** moves below exhaust port **72** to permit exit of the exhaust gasses. Piston **34** then reaches bottom dead center (BDC) and begins moving away from crankshaft **42**. The soot zone is located at injection angles E and F (e.g., approximately 90 and 150 degrees) before top dead center (BTDC). The compression stroke then begins once exhaust port **72** is closed. Within the range of angles indicated in dashed lines as spark angles, a control unit energizes spark plug **56** to ignite the air-fuel mixture in combustion chamber **52**.

An electronic control unit, described in more detail below, utilizes a map stored in memory to control fuel injection angles and spark angles based on throttle position and rpm. This control unit also stores a fuel map that controls, subject to correction based on the output of sensor **76**, the quantities of fuel injected into each cylinder. In an exemplary engine at idle speed, the pistons move from TDC to BDC and back to TDC in about 100 milliseconds. At 6000 engine RPMs, the pistons move from TDC to BDC and back to TDC in

about 10 milliseconds. Accordingly, the engine speed or RPM influences the angle or degrees before TDC at which fuel is injected into the cylinders, because it influences the fuel residence time needed for mixing and evaporation. For example, at wide open throttle, fuel might be injected into the cylinder at about 220 before top dead center, but as the speed of the piston decreases during throttle back, the angle at which fuel is injected also decreases.

Under the step or skip strategy, the engine fuel injection angle is controlled so that the soot zone is avoided in each cylinder. That is, the fuel injection angles for all the cylinders are the same and when the throttle position is advanced to a position corresponding to an injection angle proximate the soot zone, individual cylinders are controlled to skip through the soot zone one at a time. In accordance with the skip strategy, a first set of throttle positions provides for engine operation in a stratified combustion mode and the fuel injection angles in all the cylinders are the same. For a second set of throttle positions, the engine operates in a mixed stratified combustion mode and homogeneous combustion mode in that the injection angles in at least one of the cylinders result in stratified combustion and the injection angles in at least one of the other cylinders result in homogeneous combustion. For a third set of throttle positions, the engine operates in a homogeneous mode, and the fuel injection angles in all the cylinders are the same. This engine control strategy effectively allows individual cylinders to skip the soot zone individually or in small groups, e.g. pairs. When the oxygen sensor 76 is placed in the first individual or group of cylinders to move from stratified combustion mode to homogeneous combustion mode, appropriate correction factors can be determined as soon as possible and applied to the other cylinders, typically once they are moved into the homogeneous combustion mode.

In one embodiment, at throttle positions up to 15 percent of wide open throttle, the injection angles in all the cylinders are the same, and the engine operates in a stratified combustion mode. Upon increasing throttle position, between throttle positions of approximately 15 percent and 27.5 percent of wide open throttle, one or more cylinders are now controlled to operate with earlier injection angles and higher fueling, which results in higher torque production and lower soot formation than the soot zone (e.g., between 90 and 150 degrees BTDC). Simultaneously, the remaining cylinders operate with late injection angles and stratified low fueling, resulting in a stratified mixture of air and fuel, lower torque and also lower soot formation than the soot formation for the soot zone. One or more cylinders may be operating at one end, e.g. injection angle F of the soot zone, and the remaining cylinders may be operating at the other end, e.g. injection angle E of the soot zone. Once the throttle position is advanced beyond the skip range (e.g., 27.5 percent of wide open throttle), all cylinders once again are operated at the same fuel injection angles, and the engine operates in the homogeneous combustion mode.

Referring generally to FIG. 6, a graphical illustration of injection angle versus percent throttle is illustrated for the described injection angle skip strategy. Region A corresponds to stratified combustion, region B corresponds to mixed stratified and homogeneous combustion and region C corresponds to homogeneous combustion. Region B is where some cylinders are operating in a stratified combustion mode and some cylinders are operating in a homogeneous combustion mode without significantly increasing soot formation relative to regions A or C. Advantageously, the present technique allows for sequential skipping over

injection angles corresponding to the soot zone, as illustrated in FIG. 5. For example, there may be six

cylinders, such as cylinders C1, C2, C3, C4, C5 and C6, which sequentially skip over the injection angles between E and F corresponding to Region B (the soot zone). Thus, the soot zone is avoided, and the process of sequentially skipping through the soot zone ensures a smoother transition.

FIG. 7 illustrates an exemplary torque curve and boat load curve versus percent throttle for an exemplary engine utilizing the present technique. As graphically represented in FIG. 7, the torque curve has a relatively smooth transition through regions A, B and C. In regions A and C, all cylinders produce approximately equal torque, while in region B the cylinders operating in homogeneous combustion mode produce a greater torque than those operating in stratified combustion mode. However, the torque curve remains relatively smooth throughout the transition due to the gradual change from stratified to homogeneous combustion. Also, the homogeneous cylinders are specifically trimmed down immediately after the skip.

Referring generally to FIG. 8, a schematic representation of engine 12 is illustrated as coupled to a control system 78. The exemplary engine 12 includes six cylinders 18 each coupled to a fuel injector 54 designed to inject fuel directly into the corresponding cylinder 18.

An exemplary control system 78 includes an electronic control unit 80 coupled to a plurality of sensors 82 that sense such parameters as engine speed, throttle position, exhaust pressure and engine temperature. The output from sensors 82 is directed to an injector controller 84 in which one or more fuel maps are stored. Based on the input from sensors 82, injector controller 84 decides the appropriate quantity of fuel, e.g. gasoline, to inject into each of the cylinders 18 according to the fuel map.

In this particular embodiment, injector controller 84 continually varies the amount of fuel injected into the sensed cylinder to which combustion sensor 76 is coupled for determination of oxygen content in the exhaust gas. In the embodiment illustrated in FIG. 8, an individual cylinder 18 (labeled as cylinder #6) is connected to combustion sensor 76. Based on the output of combustion sensor 76, the fuel quantity injected at the sensed cylinder is either increased or decreased depending on whether the sensor indicates the fuel mixture to be lean or rich relative to a stoichiometric mixture. The periodic adjustment to the fuel quantity injected into the sensed cylinder (cylinder #6) is controlled by a sensed cylinder correction control 86.

As the stoichiometric mixture is continually determined at varying inputs from sensors 82, the amount of fuel actually injected to achieve the stoichiometric mixture is compared to the fuel map value stored at injector controller 84. The comparison permits determination of a correction factor based on the ratio of the actual fuel required for stoichiometric combustion versus the fuel map value established to achieve stoichiometric combustion.

Preferably, the correction factors are averaged over a predetermined number of engine cycles by a correction averaging module 88 of electronic control unit 80. The number of cycles over which the correction factors are averaged can vary according to engine and operating conditions (e.g., percent throttle, speed, and temperature), use, fuel and application. The average of this correction factor is then applied to the fuel map values for the nonsensed cylinders (e.g. cylinder #s 1, 2, 3, 4, and 5) via a non-sensed cylinder correction module 90. The altered or corrected fuel quantities are supplied to an injection driver 92 that adjusts

the quantities injected into the non-sensed cylinders. Typical injectors **54** are solenoid-based injectors that can be controlled through adjustment of the pulse width to inject more or less fuel. Injector driver **92** increases the pulse width to inject a greater amount of fuel and decreases the pulse width to inject a lesser amount of fuel.

Even though the sensed cylinder is controlled to constantly determine stoichiometric combustion, the correction factor is applied to the non-sensed cylinders whether or not the desired operation is at a stoichiometric mixture. For example, at given inputs from sensors **82**, the fuel map stored in injector controller **84** may be established to provide a richer mixture than stoichiometric. Even so, the correction factor is applied to the fuel map for the non-sensed cylinders. Thus, an inexpensive combustion sensor **76**, e.g. a passive oxygen sensor, coupled to an individual cylinder can be used to improve operation of engine **12** even when the desired operation of the non-sensed cylinders is not at stoichiometric combustion mixtures.

In an exemplary operation, if the output of combustion sensor **76** indicates that the fuel map stored in injector controller **84** for stoichiometric operation is actually 5 percent lean of stoichiometric, then the fuel map may be adjusted by a correction factor of 5 percent. This correction factor is applied in the form of more fuel delivered to the non-sensed cylinders than indicated by the fuel map. Specifically, if the desired operating condition in the non-sensed cylinders is actually 10 percent rich of stoichiometric according to the stored map values for non-sensed cylinders, then the fuel map may be corrected by a percentage (e.g., 5–15 percent) to increase the quantity of fuel injected (e.g., 5–15 percent increase) to the non-sensed cylinders. Therefore, a target air-fuel ratio map may be set at conditions other than stoichiometric (e.g., 10 percent rich), and the cylinders may be adjusted accordingly. It should also be noted that the control unit **80** may be programmed to store the corrected fuel map for future application when under those particular operating conditions.

As illustrated in FIG. 9, it may be desirable to apply correction factors only if the engine is operating within a certain zone. For example, oxygen sensors can be used to more accurately determine air-fuel mixtures when a two-stroke is operated in homogeneous mode. Furthermore, if the control system is utilized with a skip strategy, as described above, it can be important to utilize the correction factor only for cylinders that have entered the homogeneous combustion mode. For such applications, a decision algorithm **94** is utilized by injector controller **84**.

Injector controller **84** utilizes operational mode flags **96** (e.g., injection angle) to maintain track of whether a given cylinder is operating in a stratified combustion mode or a homogeneous combustion mode. According to decision algorithm **94**, an operating mode flag for each cylinder is periodically polled or checked, as indicated by block **98**. Based on the operating mode flag, a determination is made whether the particular cylinder is operating in homogeneous combustion mode, as indicated by block **100**. If not, the injection driver is utilized according to the stored fuel map values without correction, as indicated by block **102**. If, however, the homogeneous combustion mode has been attained, the correction factor is applied to that particular cylinder, as indicated by block **104**. Further, the correction factor may be slowly phased in to smooth the transition.

Referring generally to FIGS. 11–13, a preferred embodiment of a sensor assembly **106** includes sensor **76**, such as a passive oxygen sensor, coupled to the sensed cylinder **18**.

Sensor assembly **106** includes a sampling passage **108** that extends through a cylinder wall **110** of cylinder **18**. Sampling passage **108** is in fluid communication with the interior of cylinder **18** and is disposed at a location intermediate exhaust port or ports **72** and the top of cylinder **18** (generally defined as the top of piston **34** when piston **34** is disposed at top dead center within cylinder **18**). External to cylinder **18**, sampling passage **108** is blocked by a valve **112**, such as a spring-loaded, pressure-release valve.

A sensor chamber **114** defined by a chamber wall **116** surrounds valve **112** and an outlet **118** of sampling passage **108**. Sensor chamber **114** includes a liquid collection region **120** and a drain outlet **122** positioned to drain liquid that may collect in liquid collection region **120**. Preferably, chamber wall **116** includes a mounting region **124** designed to receive sensor **76** by, for instance, threaded engagement. Mounting structure **124** includes an internal opening **126** that permits communication of a sensory tip **128** of sensor **76** with sensor chamber **114**.

Valve **112** may comprise a variety of valves, such as reed valves or other types of spring-loaded valves. For example, in the illustrated embodiment, valve **112** utilizes a spring-loaded plate that is securely held over exit **118** of sampling passage **108** by a spring **132**. Spring **132** is held against plate **130** by an adjuster **134**, such as a threaded bolt that is inserted through the center of spring **132** and plate **130** for threaded engagement with a bore **136**. Thus, the adjuster **134** can be tightened or loosened against spring **132** to hold spring-loaded plate **130** over exit **118** with greater or lesser force. This permits regulation of the amount of pressure in cylinder **18** that is required to open valve **112** to permit the escape of exhaust gas into sensor chamber **114**, as illustrated in FIG. 12.

Additionally, sensor assembly **106** includes an outflow diverter **138** positioned to divert the flow of exhaust gas through sampling passage **108** such that the exhaust gas is not forced directly against sensor tip **128**. The exhaust gas can contain fuel or oil droplets that detrimentally affect the operation of sensor **76** if permitted to contact sensor tip **128**. In the illustrated embodiment, diverter **138** comprises a cupped portion **140** attached to spring plate **130** to divert the exhaust gas and any droplets or particles away from sensor tip **128**. The liquid and particulate matter settles into liquid collection region **120** and is purged from sensor chamber **114** via drain outlet **122**.

Drain outlet **122** can be arranged in a variety of configurations depending on the desired return flow. For example, the liquid collection region **120** can be placed in communication with an upper part of the exhaust port of the sensed cylinder or another cylinder; the liquid collection region may be placed in communication with the lower part of the exhaust system where the pressure waves will not create a backflow of exhaust gas into the chamber; the chamber may be placed in communication with a part of the exhaust system via another check valve that will only allow flow of gas out of the chamber and thus prevent any gas other than combustion gas from entering the chamber; the collection region may be placed in communication with the crankcase at the same cylinder; or the collection region may be placed in communication with the crankcase of another cylinder selected so that the crankcase pressure supports the purging of the sensor chamber.

It will be understood that the foregoing description is of preferred exemplary embodiments of this invention, and that the invention is not limited to the specific form shown. For example, the present invention potentially can be used with

## 11

both two-stroke and four-stroke engines. A variety of fuel delivery systems can be used other than the direct fuel injection system described above. Additionally, although the engine control system and methodology have been described in the context of a marine engine, the invention may be utilized in a variety of other applications.

Also, the terms "stratified combustion" and "homogeneous combustion" should not be limited to pure stratified combustion and pure homogeneous combustion. Generally, there is a transition between pure stratified and pure homogeneous combustion. Therefore, the term "stratified combustion" refers both to pure stratified combustion and combustion which is more stratified than homogeneous, and the term "homogeneous combustion" refers to both pure homogeneous combustion and combustion which is more homogeneous than stratified. Furthermore, a variety of sensors and control systems or control system parameters can be incorporated into the design without departing from the scope of the present invention. These and other modifications may be made in the design and arrangement of the elements without departing from the scope of the invention as expressed in the appended claims.

What is claimed is:

1. A method for controlling the operation of an internal combustion engine having a plurality of cylinders and a controller that utilizes a fuel map, comprising:
  - creating a reference combustion condition in a sensed cylinder of the internal combustion engine;
  - sensing the reference combustion condition;
  - determining whether the reference combustion condition is a desired combustion condition;
  - adjusting a first fuel amount introduced to the sensed cylinder to move the combustion condition towards the desired combustion condition to determine a desired first fuel amount; and
  - correcting a second fuel amount introduced into a non-sensed cylinder based on the a comparison of the desired first fuel amount and a current operating parameter fuel amount.
2. The method as recited in claim 1, wherein sensing comprises sensing for a level of oxygen in an exhaust gas produced in the sensed cylinder.
3. The method as recited in claim 2, wherein sensing includes sensing the reference combustion condition in a two-stroke engine.
4. The method as recited in claim 3, wherein determining comprises determining whether the reference combustion condition in the sensed cylinder is stoichiometric combustion.
5. The method as recited in claim 4, wherein the desired combustion condition is stoichiometric combustion.
6. The method as recited in claim 5, further comprising comparing the desired first fuel amount needed to achieve stoichiometric combustion with the current operating fuel amount stored in the fuel map to determine a correction factor.
7. The method as recited in claim 6, wherein correcting comprises applying the correction factor to the non-sensed cylinder when operated at a desired, non-stoichiometric air-fuel mixture.
8. The method as recited in claim 7, further comprising directly injecting fuel into the sensed cylinder and the non-sensed cylinder.
9. The method as recited in claim 8, wherein correcting comprises correcting the second fuel amount introduced into a plurality of non-sensed cylinders.

## 12

10. The method as recited in claim 9, wherein correcting the second fuel amount includes sequentially changing the second fuel amount introduced into the plurality of non-sensed cylinders to prevent an abrupt power change.

11. The method as recited in claim 1, further comprising selecting the desired combustion condition as stoichiometric combustion in the sensed cylinder while the non-sensed cylinder is operating with a desired, non-stoichiometric combustion condition.

12. A method for controlling the operation of a watercraft, comprising:

- powering the watercraft with an internal combustion engine having a plurality of cylinders;
- sensing a combustion condition in a sensed cylinder of the internal combustion engine;
- determining whether the combustion condition is a desired combustion condition;
- adjusting a first fuel amount introduced to the sensed cylinder to move the combustion condition towards a desired combustion condition to determine a desired first fuel amount; and
- correcting a second fuel amount introduced into a non-sensed cylinder based on a comparison of the desired first fuel amount and a current operating parameter fuel amount.

13. The method as recited in claim 12, wherein sensing comprises sensing for a level of oxygen in an exhaust gas produced in the sensed cylinder.

14. The method as recited in claim 13, wherein sensing includes sensing the combustion condition in a two-stroke engine.

15. The method as recited in claim 14, wherein determining comprises determining whether the desired combustion condition in the sensed cylinder is stoichiometric combustion.

16. The method as recited in claim 12, wherein adjusting comprises adjusting the first fuel amount introduced into the sensed cylinder to move the combustion condition towards stoichiometric combustion.

17. The method as recited in claim 16, further comprising comparing the desired first fuel amount actually delivered to the sensed cylinder to achieve stoichiometric combustion with a predetermined amount stored in a fuel map to determine a correction factor for achieving stoichiometric combustion.

18. The method as recited in claim 17, wherein correcting comprises applying the correction factor to the non-sensed cylinder when operated at a desired, non-stoichiometric air-fuel mixture.

19. The method as recited in claim 18, further comprising directly injecting fuel into the sensed cylinder and the non-sensed cylinder.

20. The method as recited in claim 19, wherein correcting comprises correcting the second fuel amount introduced into a plurality of non-sensed cylinders.

21. The method as recited in claim 20, wherein correcting the second fuel amount includes sequentially changing the amount of fuel introduced into the plurality of non-sensed cylinders to prevent an abrupt power charge.

22. The method as recited in claim 12, further comprising selecting the desired combustion condition as stoichiometric combustion in the sensed cylinder while the non-sensed cylinder may be operating with a desired, non-stoichiometric combustion condition.

23. The method as recited in claim 12, wherein powering comprises powering a boat.

13

- 24. The method as recited in claim 12, wherein powering comprises powering a personal watercraft.
- 25. A system for controlling operation of an internal combustion engine having a plurality of cylinders and a controller that utilizes a fuel map, comprising:
  - means for sensing a combustion condition in a sensed cylinder of the internal combustion engine;
  - means for determining whether the combustion condition is a desired combustion condition;
  - means for adjusting a first fuel amount introduced to the sensed cylinder to move the combustion condition towards the desired combustion condition to determine a desired first fuel amount; and
  - means for correcting a second fuel amount introduced into a non-sensed cylinder based on a comparison of the desired first fuel amount and a current operating parameter fuel amount.
- 26. The system as recited in claim 25, wherein the means for sensing comprises an oxygen sensor.
- 27. The system as recited in claim 26, wherein the internal combustion engine comprises a direct fuel-injected two-stroke engine.
- 28. The system as recited in claim 27, wherein the desired combustion condition is stoichiometric combustion.
- 29. The system as recited in claim 28, wherein the non-sensed cylinder comprises a plurality of non-sensed cylinders operated at non-stoichiometric combustion.
- 30. A system for controlling combustion in an engine, comprising:
  - a direct, fuel-injected, two-stroke engine having a plurality of cylinders with each cylinder being coupled to a fuel injector and a pair of electrodes for producing an ignition spark;
  - a combustion condition sensor coupled to a sensed cylinder of the plurality of cylinders and able to produce an output indicative of a combustion condition;
  - a first control unit able to adjust a first fuel amount injected into the sensed cylinder such that the combustion condition moves toward a desired combustion condition; and

14

- a second control unit having a pre-established fuel map for injecting specific quantities of fuel into each cylinder under a given operating condition, wherein the fuel map for non-sensed cylinders is adjusted according to the output of the combustion condition sensor.
- 31. The system as recited in claim 30, wherein the combustion condition sensor comprises an oxygen sensor.
- 32. The system as recited in claim 31, wherein the oxygen sensor comprises a passive oxygen sensor.
- 33. The system as recited in claim 32, wherein the first fuel amount injected into the sensed cylinder is changed on a periodic basis to move an air-fuel mixture towards a desired ratio in the sensed cylinder.
- 34. The system as recited in claim 33, wherein the second control unit is configured to compare the first fuel amount actually required to obtain the desired ratio with a corresponding fuel injection value of the pre-established fuel map to establish a correction factor to achieve the desired ratio, further wherein the second control unit is configured to adjust the fuel map values for cylinders utilizing non-stoichiometric air-fuel ratios according to the correction factor.
- 35. The system as recited in claim 33, wherein the desired ratio is a stoichiometric ratio.
- 36. The system as recited in claim 34, wherein the correction factor has an initial value that the second control unit is configured to adjust according to the actual fuel amount required to obtain the desired ratio.
- 37. The system as recited in claim 34, wherein each individual fuel injector is oriented to spray fuel at the pair of electrodes in the cylinder coupled to the individual injector.
- 38. The method as recited in claim 1, further comprising storing within the fuel map a corrected current operating parameter fuel amount, wherein the corrected operating parameter fuel amount is determined by a comparison of the desired first fuel amount with the current operating parameter fuel amount.

\* \* \* \* \*