

C-6

Automatic Transmission



Options

- Transmission Mounted Parking Brake

Approximate Dimensions

Width
20.2 inches (513 mm)
Height
16.4 inches (417 mm)
Face to Mount
22.9 inches (582 mm)
Length
28.9 inches (734 mm)
Length with ZF Brake
32.2 inches (818 mm)
Face to Control Lever
11.5 inches (292 mm)
Bolt Pattern
Ford CSG-649

Warranty

Contact Ford Power Products for warranty details.

Specifications

Transmission TypeHydraulically Controlled (remanufactured)
Torque Capacity500 Ft-Lb. (678 Nm) after converter
Torque Capacity (110K)256 Ft-Lb. (347 Nm) before converter
Torque Capacity (140K)220 Ft-Lb. (298 Nm) before converter
Converter Stall Torque
Multiplication2.0 (110K), 2.3 (140K)
Maximum Fluid Temp250 degrees F (121 degrees C)
Continuous220 degrees F (104 degrees C)
Installation Angle4 to 6 degrees
Weight with Oil Less Brake203 lb. (90 kg)
Transmission FluidMercon
Fluid Capacity24 Pints
Engine UsageFord CSG-649 / Ford ESG-642

Gear Ratios

First Gear2.46 to 1.00
Second Gear1.46 to 1.00
Third Gear1.00 to 1.00
Reverse Gear2.18 to 1.00

Gear Range Selection

Available PositionsP-R-N-D-2-1

Parking Brake

LocationExtension Housing

Transmission Controller

TypeHydraulic Valve Body

Standard Features / Benefits

Two Speed or Three Speed Valve Body for first through third; or second and third gears only

Manual Kick-Down Lever providing lower gear selection at higher vehicle speeds

Engine Braking in Manual Low Gears for increased control



The Source for Power...
Worldwide™

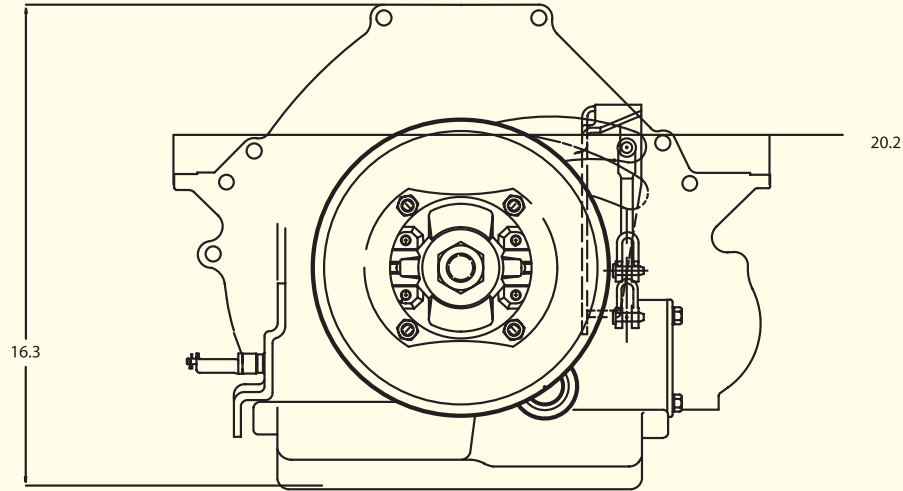

Front End View

Measurements	in
--------------	----

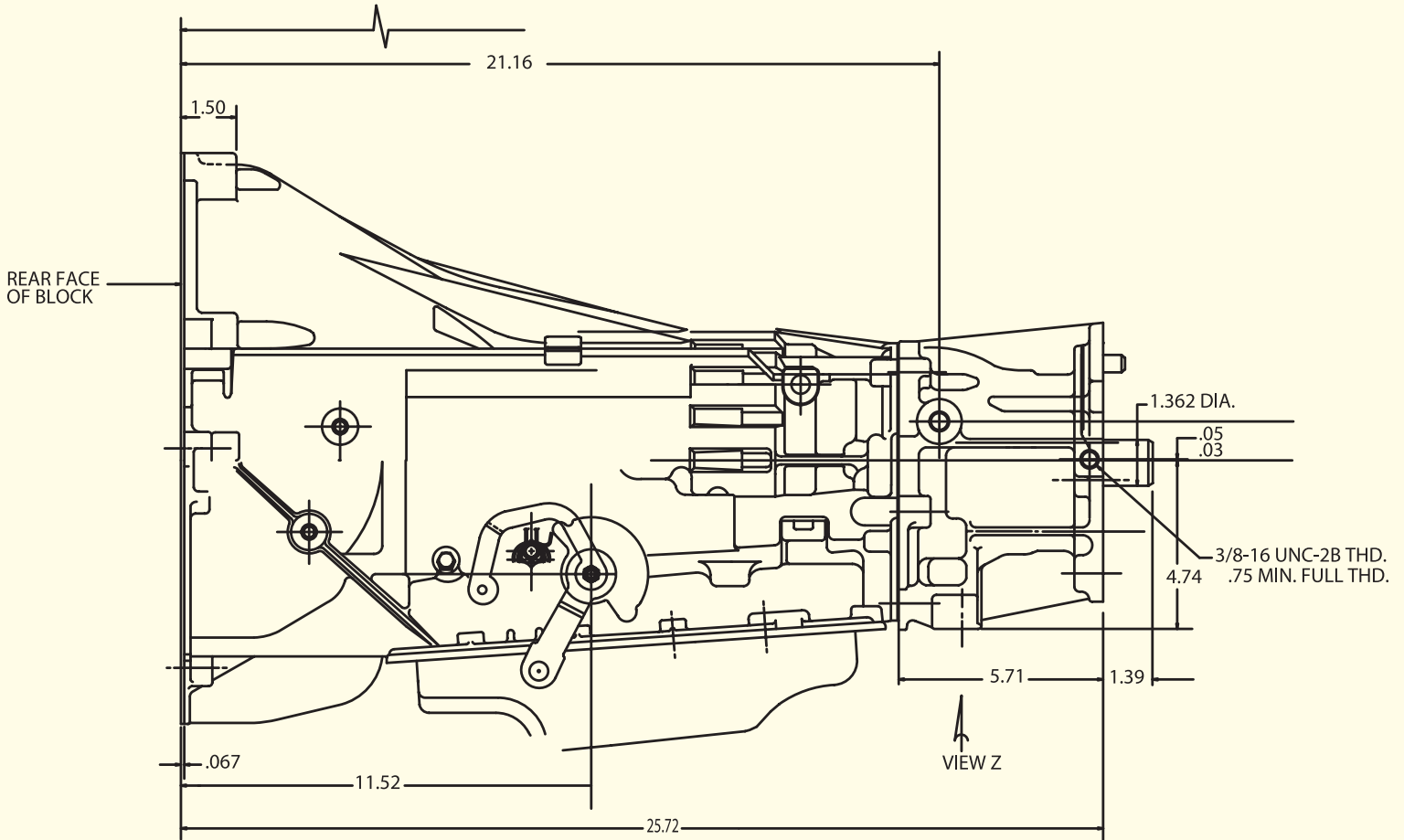

Left Side View

Specifications may vary with application and are subject to change without notice.



The Source for Power...
Worldwide™

Contact Ford Power Products or your local FPP distributor for additional information

Ford Power Products
15700 Lundy Parkway Drive
Suite 200
Dearborn, Michigan 48126
Phone: 1-800-833-4773
Fax: 1-313-619-2600

Ford Power Products GmbH
Stolberger Str. 313
D-50933 Köln, Germany
Phone: 49-221-94700-551
Fax: 49-221-94700-560

Ford Power Products Ltd.
20/586 Arisdale Avenue
South Ockendon
Essex, RM 15 5TJ England
Phone: 44-1708-672-678
Fax: 44-1708-672-349

Corporate Web Site: www.fordpowerproducts.com