

"Lambda" oxygen sensors

711 5913 = 0258 104 004

Measurement of oxygen content

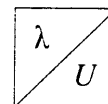

- Principle of galvanic oxygen concentration cell with solid electrolyte permits measurement of oxygen concentration, for example in exhaust-gases
- Sensor with output signal which is both stable and insensitive to interference and suitable for extreme operating conditions

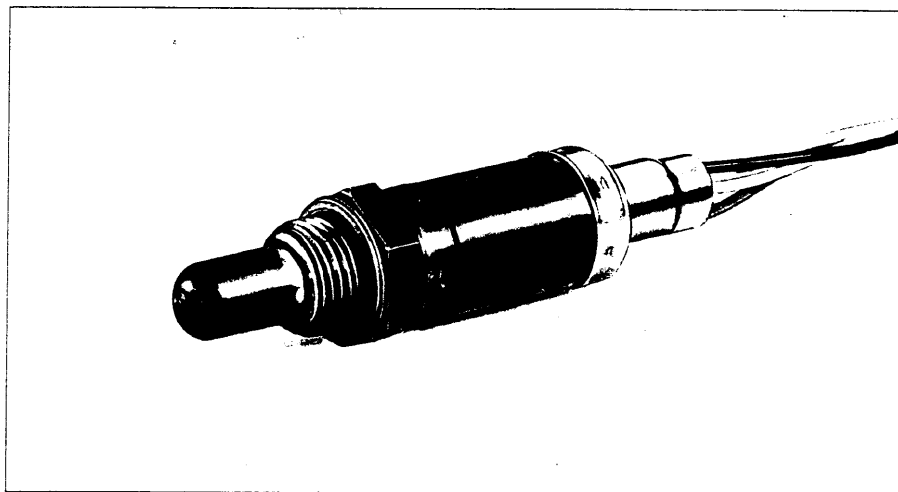

Range

O₂ Sensor

Total length 2500 mm	0 258 104 002 --
Total length 650 mm	0 258 104 004

Accessories

Connector for heating element:

Cable terminal	1 284 485 110
Receptacles ¹⁾	1 284 477 121
Protective cap	1 250 703 001

Connector for sensor:

Coupler plug	1 224 485 018
Blade terminal ¹⁾	1 234 477 014
Protective cap	1 250 703 001

Special grease for thread:

Tin 120 g	5 964 080 112
-----------	---------------

1) 5 per pack;

2 are required in each case.

Please enquire regarding Analyzing Unit LA2. This unit processes the output signals from the O₂ sensors listed here, and displays the Lambda values in digital form. At the same time, these values are also outputted through an analog output, and via a multislave V24 interface.

Technical data

Operating conditions

Temperature range, passive (storage-temperature range)	-40° ... +100 °C
Sustained exhaust-gas temperature with heater switched on	+150° ... +600 °C
Permissible max. exhaust-gas temperature with heater switched on (200 h cumulative)	+800 °C
Operating temperature at sensor-housing hexagon	≤ +500 °C
at cable gland	≤ +200 °C
at connection cable	≤ +150 °C
at connector	≤ +120 °C
Temperature gradient at the front end of the sensor ceramic	≤ +100 K/s
Temperature gradient at the sensor-housing hexagon	≤ +150 K/s
Permissible oscillation at the hexagon	
stochastic oscillations – max. acceleration	≤ 800 m · s ⁻²
sinusoidal oscillations – amplitude	≤ 0.3 mm
sinusoidal oscillations – acceleration	≤ 300 m · s ⁻²
Load current, max.	± 1 µA

Heater

Nominal supply voltage (preferably AC)	12 V _{eff}
Operation voltage	12 ... 13 V
Heater rating for $\dot{v}_{\text{Gas}} = 350$ °C and exhaust-gas flow rate ≈ 0.7 m · s ⁻¹ at 12 V heater voltage (steady-state)	≈ 16 W
Heater current at 12 V (steady-state)	≈ 1.25 A
Insulation resistance between heater and sensor connection	> 30 MΩ

Values for burner operation

Lambda control range λ	1.00...2.00
Sensor output voltage at $\lambda = 1.025$... 2.00 at $\dot{v}_{\text{Gas}} = 220$ °C and exhaust-gas flow rate 0.4 ... 0.9 m · s ⁻¹	68...3.5 mV ²⁾
Sensor internal resistance R _s in air at 20 °C and 12 V heater voltage	≤ 250 Ω
Sensor output voltage in air at 20 °C in as-new state and with 12 V heater voltage	-8.5 ... -12 mV
Manufacturing tolerance $\Delta \lambda$ in as-new state (standard deviation 1 s) at $\dot{v}_{\text{Gas}} = 220$ °C and approx. 0.7 m · s ⁻¹ flow rate	
at $\lambda = 1.30$	≤ ± 0.013
at $\lambda = 1.80$	≤ ± 0.050
Relative sensitivity $\Delta U_s / \Delta \lambda$ at $\lambda = 1.30$	0.65 mV/0.01
Influence of the exhaust-gas temperature on the sensor signal for a temperature increase from 130 °C to 230 °C, at a flow rate of ≤ 0.7 m · s ⁻¹ at $\lambda = 1.30$; $\Delta \lambda$	≤ ± 0.01
Influence of a ±10 % change of 12 V heater-voltage change at $\dot{v}_{\text{Gas}} = 220$ °C	
at $\lambda = 1.30$; $\Delta \lambda$	≤ ± 0.009
at $\lambda = 1.80$; $\Delta \lambda$	≤ ± 0.035
Response time at $\dot{v}_{\text{Gas}} = 220$ °C and flow rate approx. 0.7 m · s ⁻¹ as-new values for the 66 % switching point; λ jump = 1.10 ↔ 1.30	
for jump direction towards "lean"	2.0 s
for jump direction towards "rich"	1.5 s
Guide value for sensor's readiness for control following switch-on of oil burners and special heater: $\dot{v}_{\text{Gas}} \approx 220$ °C; flow rate approx. 1.8 m · s ⁻¹ ; $\lambda = 1.45$; O ₂ sensor in Ø 170 mm exhaust pipe	70 s
Sensor ageing $\Delta \lambda$ in heater-oil exhaust gas following 1000 h continuous burner operation with EL; Measured at $\dot{v}_{\text{Gas}} = 220$ °C	
and at $\lambda = 1.30$	≤ ± 0.012
and at $\lambda = 1.80$	≤ ± 0.052
Useful life at $\dot{v}_{\text{Gas}} < 300$ °C	In individual cases to be ascertained by customer. Guideline > 10,000 hrs

Warranty claims

As per General Terms of Delivery A 17 warranty claims can only be entertained if residue-free gaseous hydrocarbons and light fuel oil in line with DIN 51 603 are used as fuel.

2) See characteristic curve.

Dimension drawing. Dimensions after tightening with $M = 50 \cdot \text{Nm}$
 A Signal voltage, B Heater voltage, C Cable sleeve and seals,
 D Protective tube, E Protective sleeve. ws white, sw black, g gray.

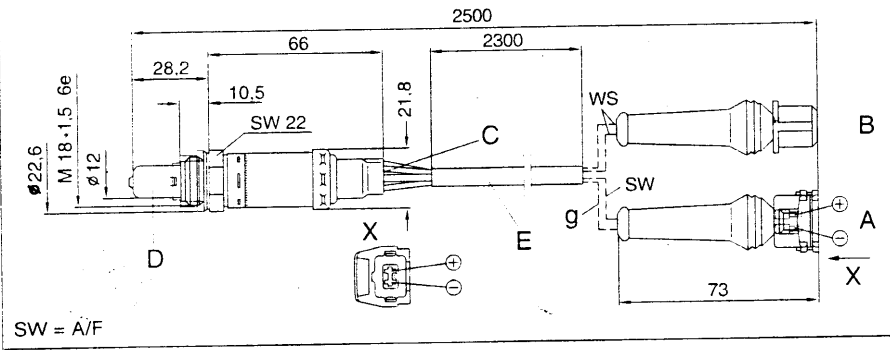

Application

- Heating systems**
- Oil burners, gas burners, coal-fired systems
- Gas engines**
- Industrial processes**
- Packaging facilities
 - Wood and refuse incineration/gasification
 - Process engineering
 - Drying installations
- Measurement and analysis**
- Gas analysis
 - O₂ portable measuring set
 - Humidity measurement

Design and function

The ceramic part of the Lambda sensor (solid electrolyte) takes the form of a tube enclosed at one end. The inside and outside surfaces of the sensor ceramic have a microporous platinum layer (electrode) which, on the one hand, has a crucial influence on the sensor characteristic due to its catalytic effect and, on the other, is used for contacting purposes. The platinum layer on that part of the sensor ceramic which is in contact with the exhaust-gas is covered with a firmly bonded, highly porous protective ceramic layer which prevents the residues in the exhaust gas from eroding the catalytic platinum layer. The sensor thus features good long-time stability. The sensor protrudes into the flow of exhaust gas and is designed such that the exhaust gas flows around one electrode, whilst the other electrode is in connection with the outside air (atmosphere). Measurements are taken of the residual oxygen content in the exhaust gas. The catalytic effect of the electrode surface at the sensor's exhaust-gas end produces a step type sensor-voltage profile in the area around $\lambda = 1.1$)

The active sensor ceramic (ZrO₂) is heated from inside by way of a ceramic heater so that the temperature of the sensor ceramic remains above the 350 °C function limit irrespective of the temperature of the exhaust gas. The ceramic heater features a PTC characteristic, which results in rapid warm-up and restricts the power requirement in the event of hot exhaust gas. The connections of the heating element are completely decoupled from the sensor signal voltage ($R \geq 30 \text{ M}\Omega$). Additional design measures serve to stabilize the lean characteristic-curve profile of the Lambda sensor at $\lambda > 1.0 \dots 1.5$ (for special applications up to $\lambda = 2.0$):

- Use of powerful heater (16 W),
- special design of protective conduit,
- modified electrode/protective layer system.

The special design makes for:

- Reliable control even with low exhaust-gas temperatures (e.g. with internal-combustion engines at idle),
- flexible installation unaffected by external heating,
- hardly any dependence of function parameters on exhaust-gas temperature,
- low exhaust-gas values thanks to the sensor's high-speed dynamic response,
- little danger of contamination and thus long service life,
- waterproof sensor housing.

Installation instructions

The Lambda sensor should be installed at a location which guarantees a representative exhaust-gas composition whilst complying with the prescribed temperature limits. The installation location is arbitrary; fitting is effected by screwing the sensor into a corresponding mating thread with a tightening torque of 50 ... 60 N · m. Special grease is to be applied to the thread.

The sensor is to be covered when painting a heating-burner system or treating it with oil etc.

Lambda sensor in exhaust pipe (principle)
 1 Sensor ceramic, 2 Electrodes, 3 Contact, 4 Housing contact, 5 Exhaust pipe, 6 Ceramic protective coating (porous).

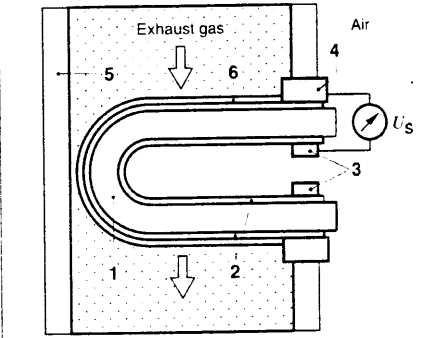

Characteristic curve: Propane gas (lean range)

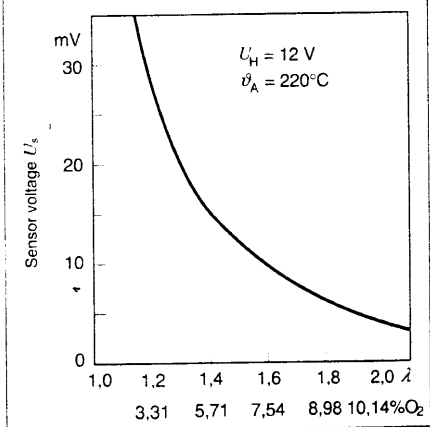

Characteristic curve: Complete range
 1 Closed-loop control $\lambda = 1$; 2 Lean control
 a Rich A/F mixture, b Lean A/F mixture.

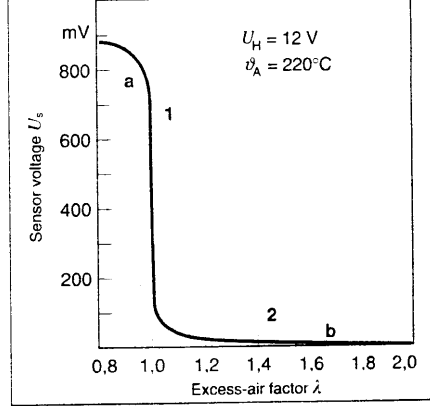

Explanation of symbols:

- U_s Sensor voltage
- U_H Heater voltage
- θ_A Exhaust-gas temperature
- λ Excess-air factor¹⁾
- O₂ Oxygen concentration in %

¹⁾ The excess air factor lambda (λ) is the ratio between the actual and the ideal air/fuel ratio.