



Low Noise, Low Power, 100 Taps

X9317

Digitally Controlled Potentiometer (XD_{CP}TM)

FEATURES

- Solid-state potentiometer
- 3-wire serial interface
- 100 wiper tap points
 - Wiper position stored in nonvolatile memory and recalled on power-up
- 99 resistive elements
 - Temperature compensated
 - End to end resistance range $\pm 20\%$
 - Terminal voltage, 0 to V_{CC}
- Low power CMOS
 - $V_{CC} = 2.7V$ or $5V$
 - Active current, $50/400\mu A$ max.
 - Standby current, $1\mu A$ max.
- High reliability
 - Endurance, 100,000 data changes per bit per register
 - Register data retention, 100 years
- R_{TOTAL} values = $1K\Omega$, $10K\Omega$, $50K\Omega$
- Packages
 - 8-lead SOIC, TSSOP and DIP

DESCRIPTION

The Xicor X9317 is a digitally controlled potentiometer (XD_{CP}). The device consists of a resistor array, wiper switches, a control section, and nonvolatile memory. The wiper position is controlled by a 3-wire interface.

The potentiometer is implemented by a resistor array composed of 99 resistive elements and a wiper switching network. Between each element and at either end are tap points accessible to the wiper terminal. The position of the wiper element is controlled by the CS, U/D, and INC inputs. The position of the wiper can be stored in nonvolatile memory and then be recalled upon a subsequent power-up operation.

The device can be used as a three-terminal potentiometer or as a two-terminal variable resistor in a wide variety of applications including:

- control
- parameter adjustments
- signal processing

BLOCK DIAGRAM

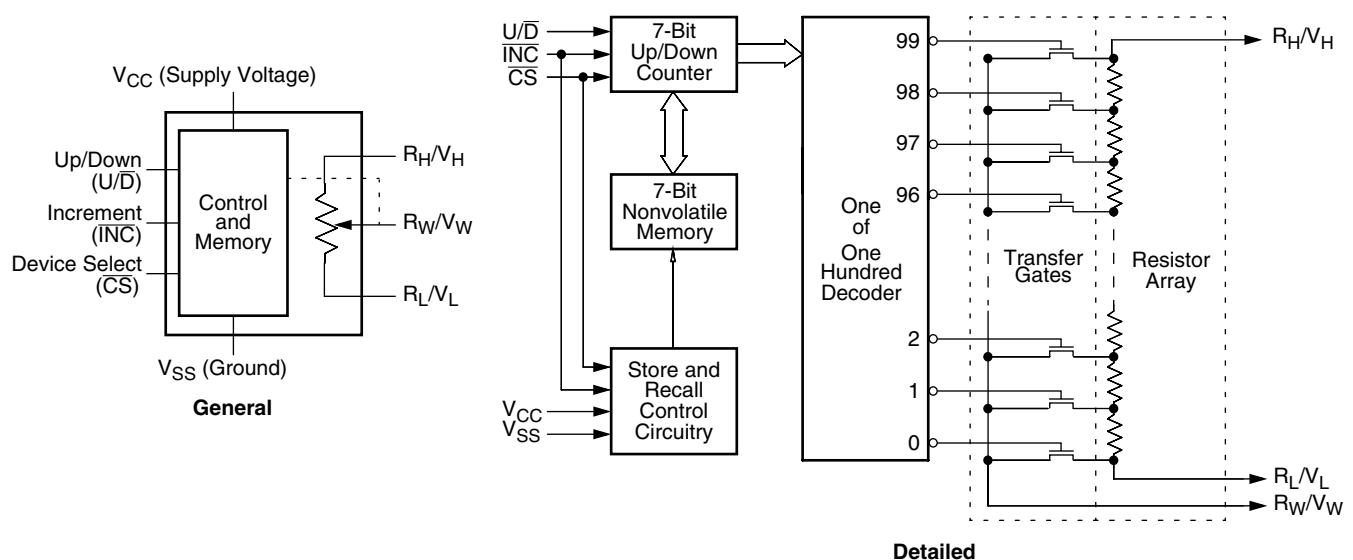

X9317

PIN DESCRIPTIONS

R_H/V_H and R_L/V_L

The high (R_H/V_H) and low (R_L/V_L) terminals of the X9317 are equivalent to the fixed terminals of a mechanical potentiometer. The minimum voltage is V_{SS} and the maximum is V_{CC} . The terminology of R_L/V_L and R_H/V_H references the relative position of the terminal in relation to wiper movement direction selected by the U/\bar{D} input and not the voltage potential on the terminal.

R_W/V_W

R_W/V_W is the wiper terminal and is equivalent to the movable terminal of a mechanical potentiometer. The position of the wiper within the array is determined by the control inputs. The wiper terminal series resistance is typically 200Ω when $V_{CC} = 5V$.

Up/Down (U/\bar{D})

The U/\bar{D} input controls the direction of the wiper movement and whether the counter is incremented or decremented.

Increment (\bar{INC})

The \bar{INC} input is negative-edge triggered. Toggling \bar{INC} will move the wiper and either increment or decrement the counter in the direction indicated by the logic level on the U/\bar{D} input.

Chip Select (\bar{CS})

The device is selected when the \bar{CS} input is LOW. The current counter value is stored in nonvolatile memory when \bar{CS} is returned HIGH while the \bar{INC} input is also HIGH. After the store operation is complete the X9317 will be placed in the low power standby mode until the device is selected once again.

PIN CONFIGURATION

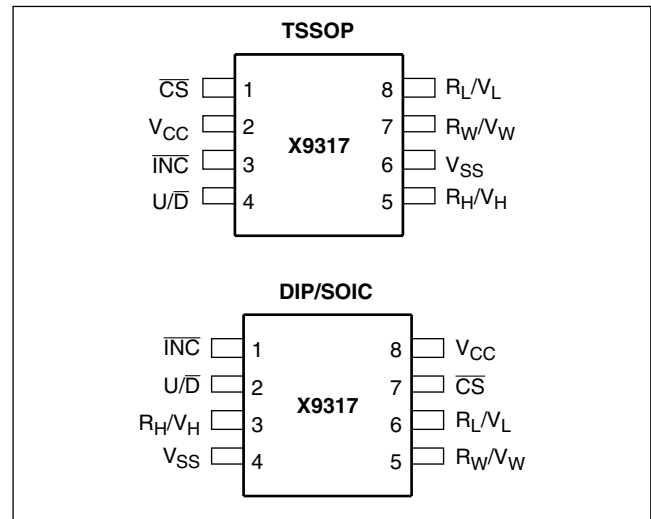

PIN NAMES

Symbol	Description
R_H/V_H	High Terminal
R_W/V_W	Wiper Terminal
R_L/V_L	Low Terminal
V_{SS}	Ground
V_{CC}	Supply Voltage
U/\bar{D}	Up/Down Control Input
\bar{INC}	Increment Control Input
\bar{CS}	Chip Select Control Input

PRINCIPLES OF OPERATION

There are three sections of the X9317: the input control, counter and decode section; the nonvolatile memory; and the resistor array. The input control section operates just like an up/down counter. The output of this counter is decoded to turn on a single electronic switch connecting a point on the resistor array to the wiper output. Under the proper conditions the contents of the counter can be stored in nonvolatile memory and retained for future use. The resistor array is comprised of 99 individual resistors connected in series. At either end of the array and between each resistor is an electronic switch that transfers the potential at that point to the wiper.

The wiper, when at either fixed terminal, acts like its mechanical equivalent and does not move beyond the last position. That is, the counter does not wrap around when clocked to either extreme.

The electronic switches on the device operate in a "make before break" mode when the wiper changes tap positions. If the wiper is moved several positions, multiple taps are connected to the wiper for t_{W} (\overline{INC} to V_W change). The R_{TOTAL} value for the device can temporarily be reduced by a significant amount if the wiper is moved several positions.

When the device is powered-down, the last wiper position stored will be maintained in the nonvolatile memory. When power is restored, the contents of the memory are recalled and the wiper is set to the value last stored.

INSTRUCTIONS AND PROGRAMMING

The \overline{INC} , U/D and \overline{CS} inputs control the movement of the wiper along the resistor array. With \overline{CS} set LOW, the device is selected and enabled to respond to the U/D and \overline{INC} inputs. HIGH to LOW transitions on \overline{INC} will increment or decrement (depending on the state of the U/D input) a seven bit counter. The output of this counter is decoded to select one of one hundred wiper positions along the resistive array.





The value of the counter is stored in nonvolatile memory whenever \overline{CS} transitions HIGH while the \overline{INC} input is also HIGH.

The system may select the X9317, move the wiper, and deselect the device without having to store the latest wiper position in nonvolatile memory. After the wiper movement is performed as described above and once the new position is reached, the system must keep \overline{INC} LOW while taking \overline{CS} HIGH. The new wiper will be maintained until changed by the system or until a power-up/down cycle recalled the previously stored data.





This procedure allows the system to always power-up to a preset value stored in nonvolatile memory; then during system operation minor adjustments could be made. The adjustments might be based on user preference, system parameter changes due to temperature drift, etc...

The state of U/D may be changed while \overline{CS} remains LOW. This allows the host system to enable the device and then move the wiper up and down until the proper trim is attained.

MODE SELECTION

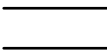
\overline{CS}	\overline{INC}	U/D	Mode
L		H	Wiper Up
L		L	Wiper Down
	H	X	Store Wiper Position
H	X	X	Standby Current
	L	X	No Store, Return to Standby

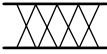
SYMBOL TABLE

WAVEFORM	INPUTS	OUTPUTS
	Must be steady	Will be steady
	May change from Low to High	Will change from Low to High
	May change from High to Low	Will change from High to Low
	Don't Care: Changes Allowed	Changing: State Not Known
	N/A	Center Line is High Impedance

X9317

ABSOLUTE MAXIMUM RATINGS

Temperature under bias-65°C to +135°C
 Storage temperature-65°C to +150°C
 Voltage on \overline{CS} , \overline{INC} , U/\overline{D} , V_H , V_L and V_{CC} with respect to V_{SS} -1V to +7V
 $\Delta V = |V_H - V_L|$ 5V
 Lead temperature (soldering 10 seconds).....300°C
 I_W (10 seconds) 8.8mA

COMMENT

Stresses above those listed under “Absolute Maximum Ratings” may cause permanent damage to the device. This is a stress rating only and the functional operation of the device at these or any other conditions above those listed in the operational sections of this specification is not implied. Exposure to absolute maximum rating conditions for extended periods may affect device reliability.

RECOMMENDED OPERATING CONDITIONS

Temperature	Min.	Max.
Commercial	0°C	+70°C
Industrial	-40°C	+85°C

Supply Voltage (V_{CC})	Limits
X9317	5V \pm 10%
X9317-2.7	2.7V to 5.5V

POTENTIOMETER CHARACTERISTICS (Over recommended operating conditions unless otherwise stated.)

Symbol	Parameter	Limits				Test Conditions/Notes
		Min.	Typ.	Max.	Unit	
R_{TOTAL}	End to End Resistance Variation			± 20	%	
$V_{H/RH}$	V_H Terminal Voltage	V_{SS}		V_{CC}	V	$V_{SS} = 0V$
$V_{L/RL}$	V_L Terminal Voltage	V_{SS}		V_{CC}	V	$V_{SS} = 0V$
	Power Rating			10	mW	$R_{TOTAL} \geq 10 K\Omega$
	Power Rating			25	mW	$R_{TOTAL} = 1 K\Omega$
R_W	Wiper Resistance		200	400	Ω	$I_W = 1mA, V_{CC} = 5V$
R_W	Wiper Resistance		400	1000	Ω	$I_W = 1mA, V_{CC} = 2.7V$
I_W	Wiper Current			± 4.4	mA	
	Noise		-120		dBV	Ref: 1kHz
	Resolution		1		%	
	Absolute Linearity ⁽¹⁾			± 1	MI ⁽³⁾	$V_{W(n)(actual)} - V_{W(n)(expected)}$
	Relative Linearity ⁽²⁾			$\pm .2$	MI ⁽³⁾	$V_{W(n+1)} - [V_{W(n)} + MI]$
	R_{TOTAL} Temperature Coefficient		± 300		ppm/°C	
	Ratiometric Temperature Coefficient			± 20	ppm/°C	
$C_H/C_L/C_W$	Potentiometer Capacitances		10/10/ 25		pF	See circuit #3

- Notes:** (1) Absolute Linearity is utilized to determine actual wiper voltage versus expected voltage = $(V_{W(n)(actual)} - V_{W(n)(expected)}) = \pm 1$ MI Maximum.
 (2) Relative Linearity is a measure of the error in step size between taps = $V_{W(n+1)} - [V_{W(n)} + MI] = \pm 0.2$ MI.
 (3) 1 MI = Minimum Increment = $R_{TOT}/99$.
 (4) Typical values are for $T_A = 25^\circ C$ and nominal supply voltage.
 (5) This parameter is periodically sampled and not 100% tested.

X9317

D.C. OPERATING CHARACTERISTICS (Over recommended operating conditions unless otherwise specified.)

Symbol	Parameter	Limits			Unit	Test Conditions
		Min.	Typ. ⁽⁴⁾	Max.		
I_{CC1}	V_{CC} Active Current (Increment)			50	μA	$\overline{CS} = V_{IL}$, $U/\overline{D} = V_{IL}$ or V_{IH} and $\overline{INC} = 0.4V/2.4V$ @ max. t_{CYC}
I_{CC2}	V_{CC} Active Current (Store) (EEPROM Store)			400	μA	$\overline{CS} = V_{IH}$, $U/\overline{D} = V_{IL}$ or V_{IH} and $\overline{INC} = V_{IH}$ @ max. t_{WR}
I_{SB}	Standby Supply Current			1	μA	$\overline{CS} = V_{CC} - 0.3V$, U/\overline{D} and $\overline{INC} = V_{SS}$ or $V_{CC} - 0.3V$
I_{LI}	\overline{CS} , \overline{INC} , U/\overline{D} Input Leakage Current			± 10	μA	$V_{IN} = V_{SS}$ to V_{CC}
V_{IH}	\overline{CS} , \overline{INC} , U/\overline{D} Input HIGH Voltage	$V_{CC} \times 0.7$		$V_{CC} + 0.5$	V	
V_{IL}	\overline{CS} , \overline{INC} , U/\overline{D} Input LOW Voltage	-0.5		$V_{CC} \times 0.1$	V	
$C_{IN}^{(5)}$	\overline{CS} , \overline{INC} , U/\overline{D} Input Capacitance			10	pF	$V_{CC} = 5V$, $V_{IN} = V_{SS}$, $T_A = 25^\circ C$, $f = 1MHz$

ENDURANCE AND DATA RETENTION

Parameter	Min.	Unit
Minimum endurance	100,000	Data changes per bit per bit
Data retention	100	Years

Test Circuit #1

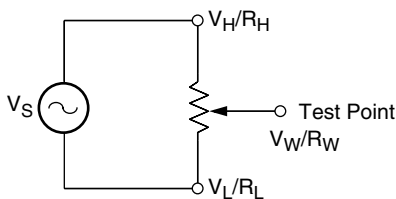

Test Circuit #2

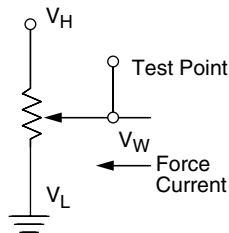

Circuit #3 SPICE Macro Model

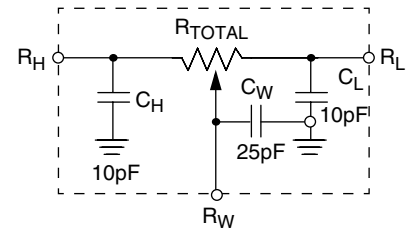

X9317

A.C. CONDITIONS OF TEST

Input pulse levels	0V to 3V
Input rise and fall times	10ns
Input reference levels	1.5V

A.C. OPERATING CHARACTERISTICS (Over recommended operating conditions unless otherwise specified)

Symbol	Parameter	Limits			Units
		Min.	Typ. ⁽⁶⁾	Max.	
t_{CI}	\overline{CS} to \overline{INC} Setup	100			ns
t_{ID}	\overline{INC} HIGH to U/\overline{D} Change	100			ns
t_{DI}	U/\overline{D} to \overline{INC} Setup	2.9			μ s
t_{IL}	\overline{INC} LOW Period	1			μ s
t_{IH}	\overline{INC} HIGH Period	1			μ s
t_{IC}	\overline{INC} Inactive to \overline{CS} Inactive	1			μ s
t_{CPH}	\overline{CS} Deselect Time (NO STORE)	100			ns
t_{CPH}	\overline{CS} Deselect Time (STORE)	10			ms
t_{IW}	\overline{INC} to V_W Change		1	5	μ s
t_{CYC}	\overline{INC} Cycle Time	4			μ s
$t_R, t_F^{(7)}$	\overline{INC} Input Rise and Fall Time			500	μ s
$t_{PU}^{(7)}$	Power up to Wiper Stable			5	μ s
$t_R V_{CC}^{(7)}$	V_{CC} Power-up Rate	0.2		50	V/ms
t_{WR}	Store Cycle		5	10	ms

A.C. TIMING

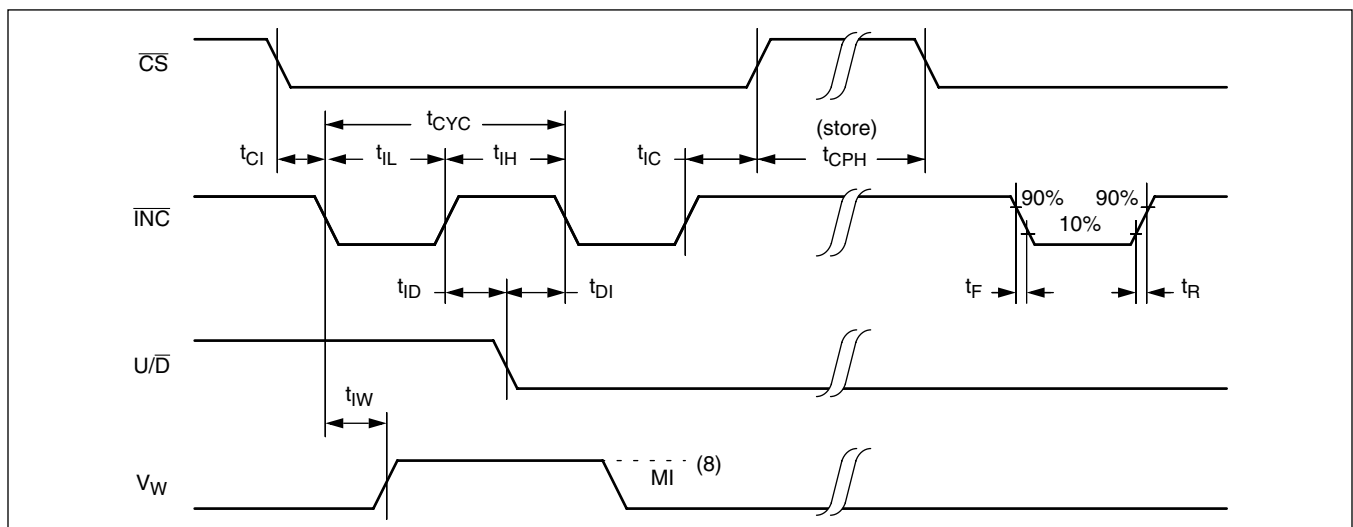

Notes: (6) Typical values are for $T_A = 25^\circ\text{C}$ and nominal supply voltage.

(7) This parameter is periodically sampled and not 100% tested.

(8) MI in the A.C. timing diagram refers to the minimum incremental change in the V_W output due to a change in the wiper position.

X9317

PERFORMANCE CHARACTERISTICS (TYPICAL)

Typical Total Resistance Temperature Coefficient

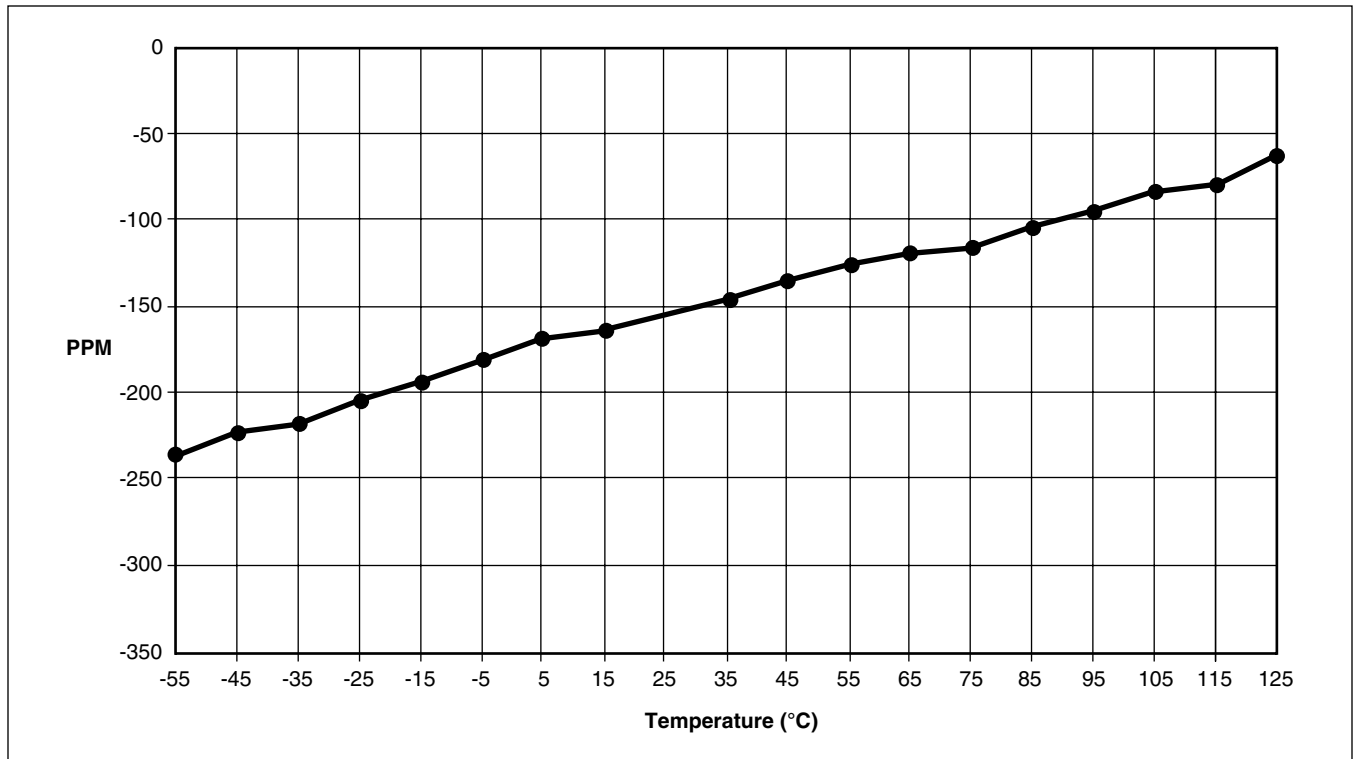

APPLICATIONS INFORMATION

Electronic digitally-controlled (XDCP) potentiometers provide three powerful application advantages; (1) the variability and reliability of a solid-state potentiometer, (2) the flexibility of computer-based digital controls, and (3) the retentivity of nonvolatile memory used for the storage of multiple potentiometer settings or data.

Basic Configurations of Electronic Potentiometers

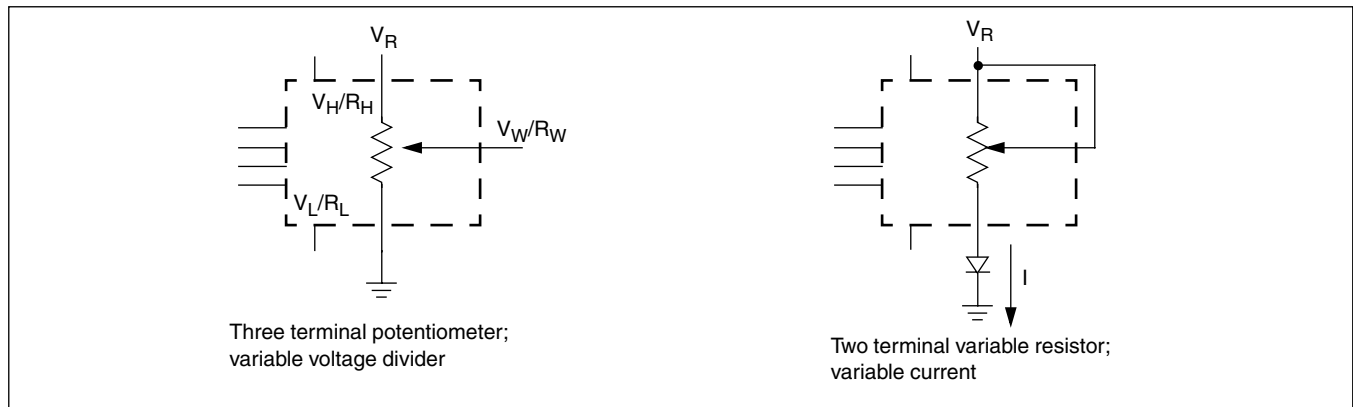

Basic Circuits

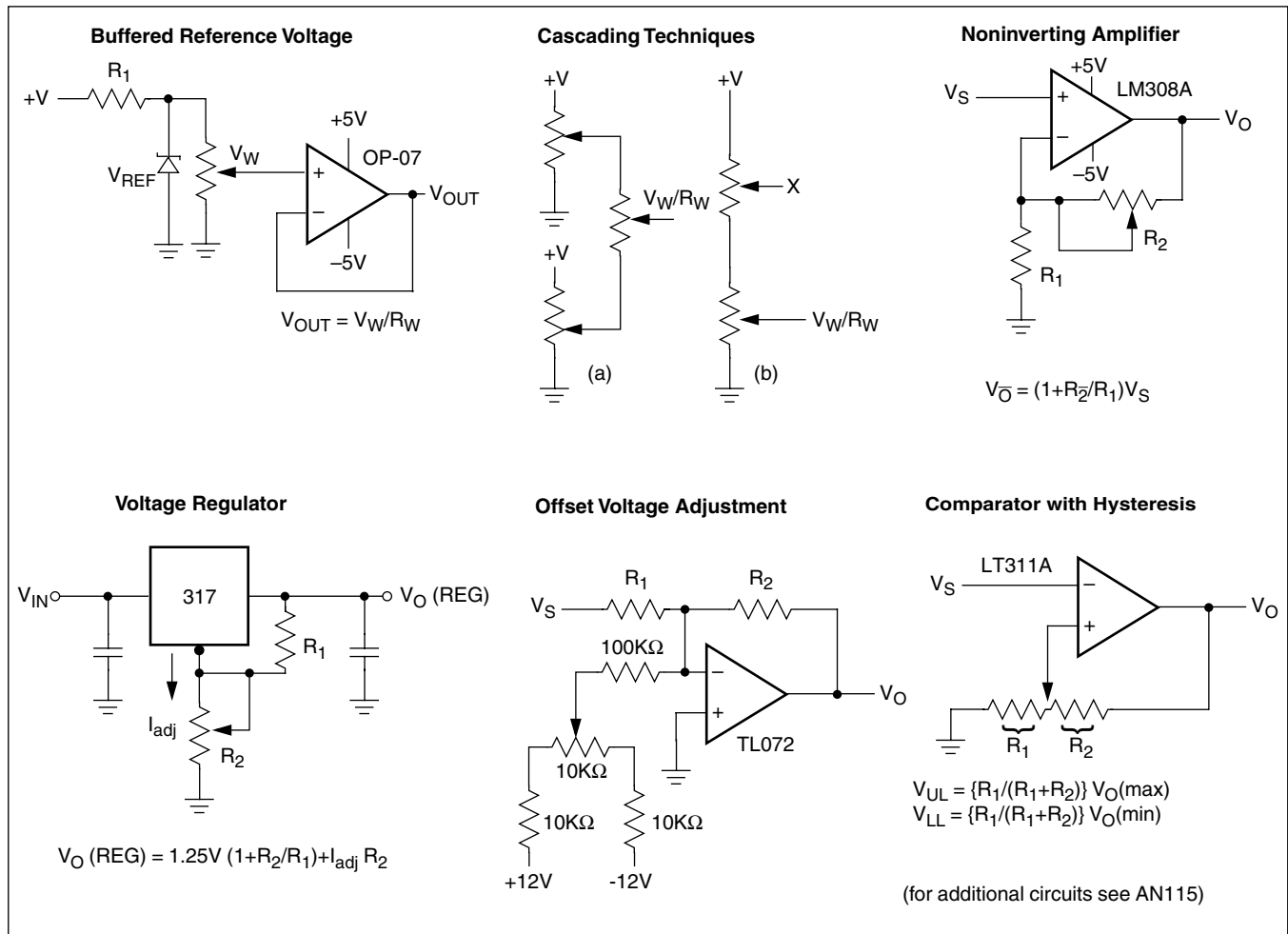

PACKAGING INFORMATION

8-Lead Plastic Dual In-Line Package Type P

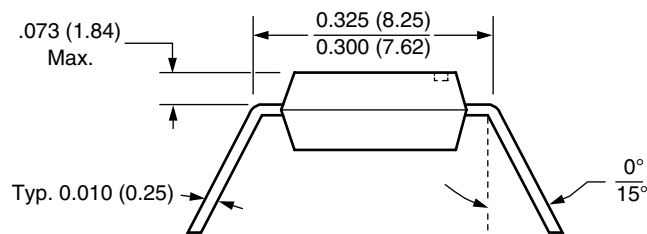
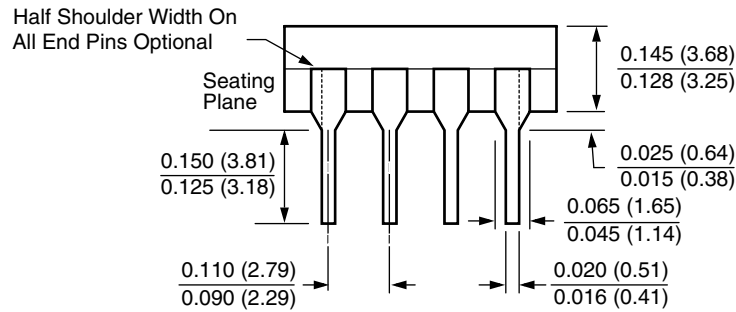
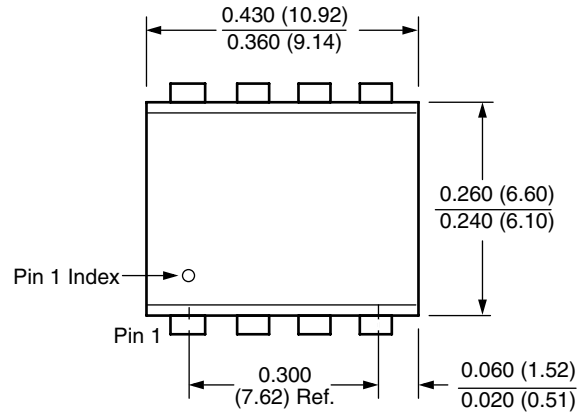

- NOTE:**
1. ALL DIMENSIONS IN INCHES (IN PARENTHESES IN MILLIMETERS)
 2. PACKAGE DIMENSIONS EXCLUDE MOLDING FLASH

X9317

PACKAGING INFORMATION

8-Lead Plastic Small Outline Gull Wing Package Type S

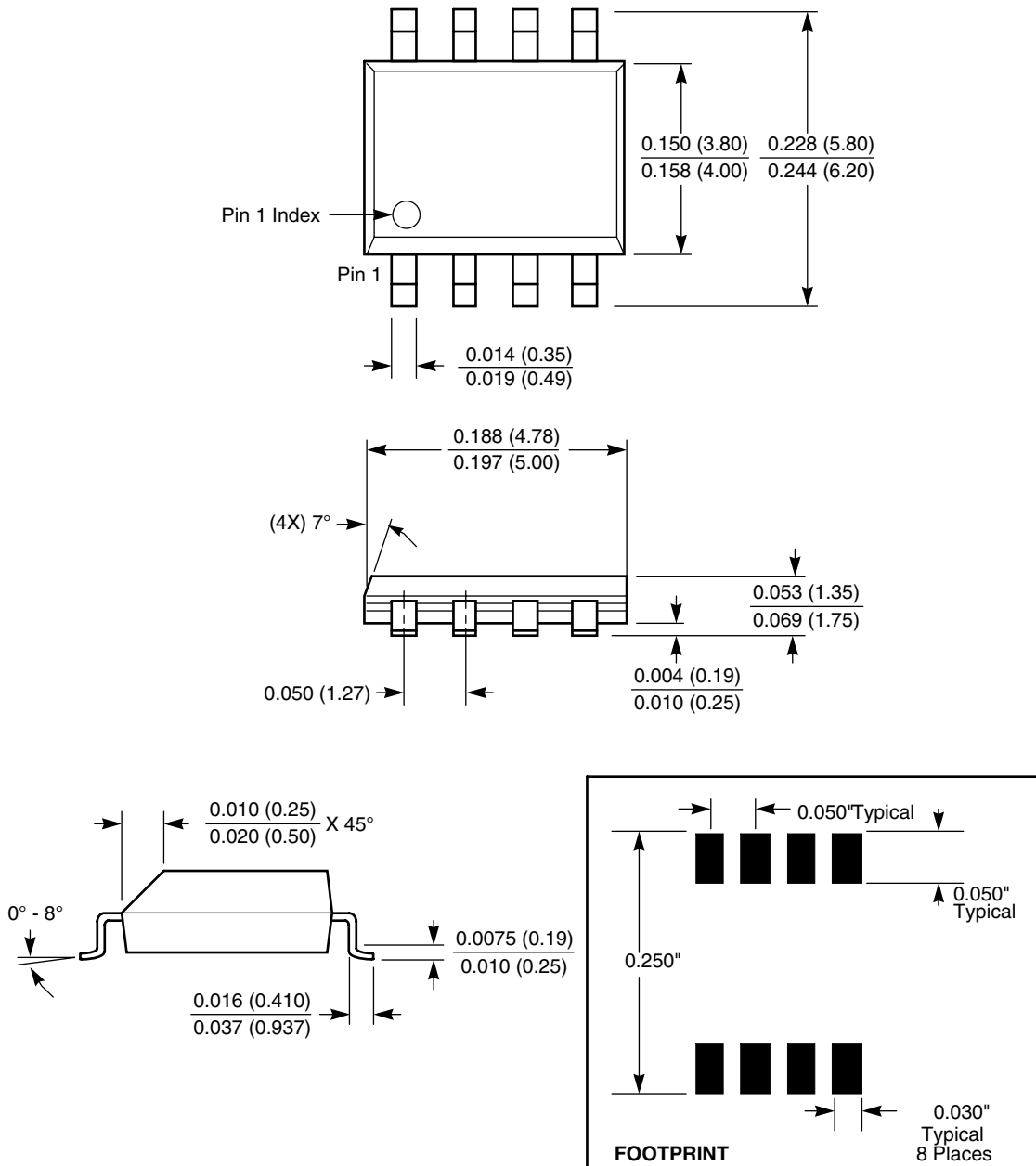

NOTE: ALL DIMENSIONS IN INCHES (IN PARENTHESES IN MILLIMETERS)

PACKAGING INFORMATION

8-Lead Plastic, TSSOP, Package Type V

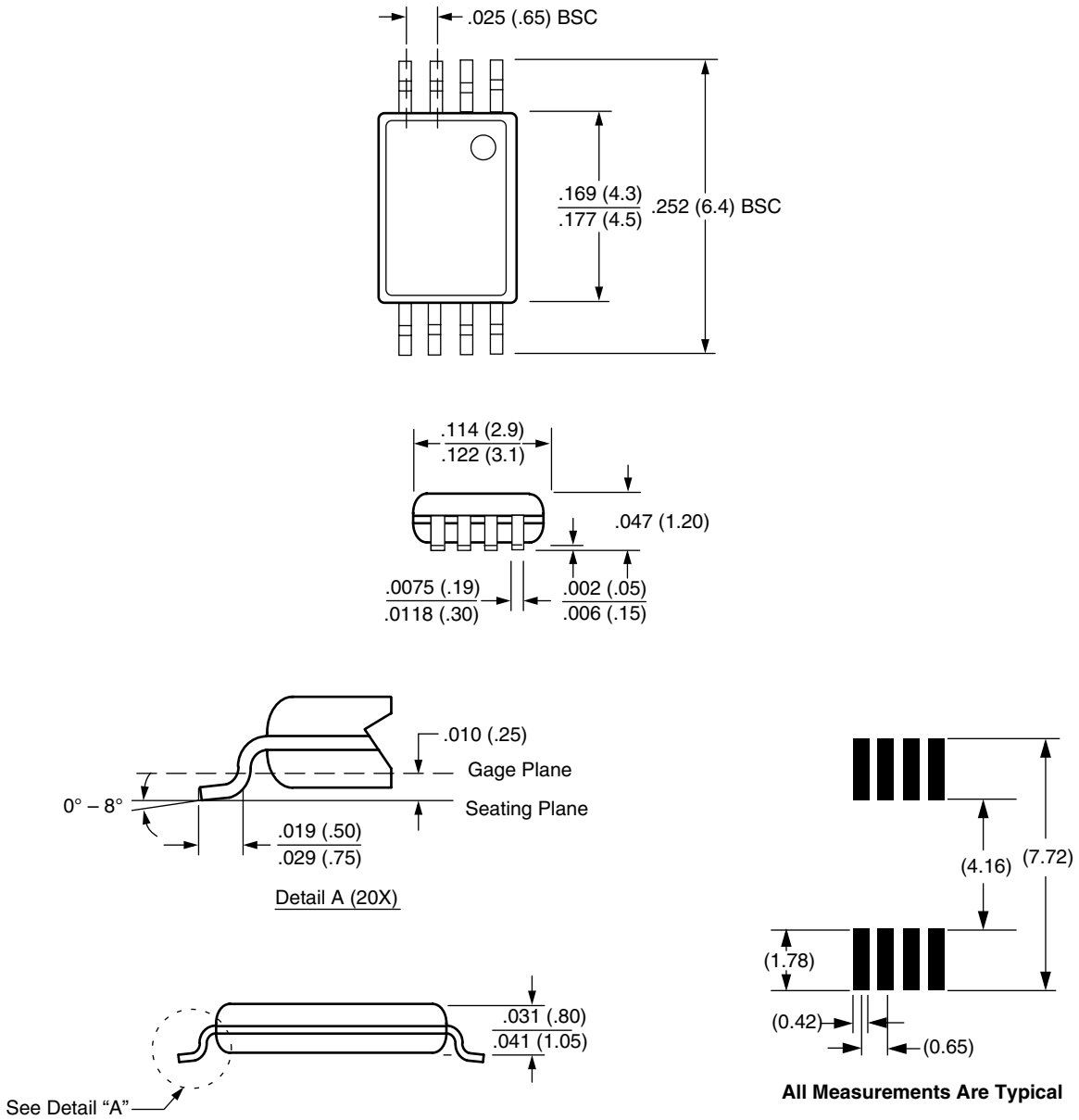

NOTE: ALL DIMENSIONS IN INCHES (IN PARENTHESES IN MILLIMETERS)

X9317

ORDERING INFORMATION

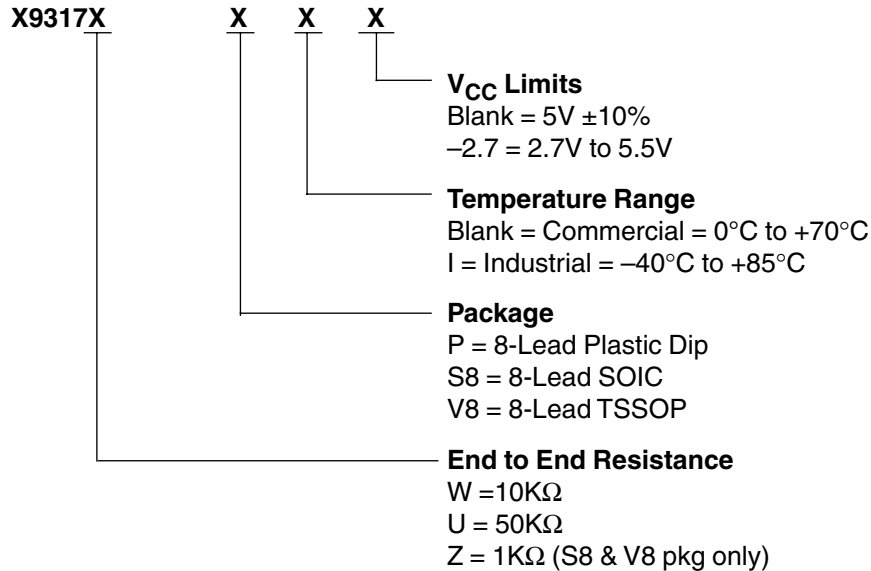

Physical Characteristics

Marking Includes
Manufacturer's Trademark
Resistance Value or Code
Date Code

LIMITED WARRANTY

©Xicor, Inc. 2000 Patents Pending

Devices sold by Xicor, Inc. are covered by the warranty and patent indemnification provisions appearing in its Terms of Sale only. Xicor, Inc. makes no warranty, express, statutory, implied, or by description regarding the information set forth herein or regarding the freedom of the described devices from patent infringement. Xicor, Inc. makes no warranty of merchantability or fitness for any purpose. Xicor, Inc. reserves the right to discontinue production and change specifications and prices at any time and without notice.

Xicor, Inc. assumes no responsibility for the use of any circuitry other than circuitry embodied in a Xicor, Inc. product. No other circuits, patents, or licenses are implied.

TRADEMARK DISCLAIMER:

Xicor and the Xicor logo are registered trademarks of Xicor, Inc. AutoStore, Direct Write, Block Lock, SerialFlash, MPS, and XDCP are also trademarks of Xicor, Inc. All others belong to their respective owners.

U.S. PATENTS

Xicor products are covered by one or more of the following U.S. Patents: 4,326,134; 4,393,481; 4,404,475; 4,450,402; 4,486,769; 4,488,060; 4,520,461; 4,533,846; 4,599,706; 4,617,652; 4,668,932; 4,752,912; 4,829,482; 4,874,967; 4,883,976; 4,980,859; 5,012,132; 5,003,197; 5,023,694; 5,084,667; 5,153,880; 5,153,691; 5,161,137; 5,219,774; 5,270,927; 5,324,676; 5,434,396; 5,544,103; 5,587,573; 5,835,409; 5,977,585. Foreign patents and additional patents pending.

LIFE RELATED POLICY

In situations where semiconductor component failure may endanger life, system designers using this product should design the system with appropriate error detection and correction, redundancy and back-up features to prevent such an occurrence.

Xicor's products are not authorized for use in critical components in life support devices or systems.

1. Life support devices or systems are devices or systems which, (a) are intended for surgical implant into the body, or (b) support or sustain life, and whose failure to perform, when properly used in accordance with instructions for use provided in the labeling, can be reasonably expected to result in a significant injury to the user.
2. A critical component is any component of a life support device or system whose failure to perform can be reasonably expected to cause the failure of the life support device or system, or to affect its safety or effectiveness.